

JET

HVBS-56M

METALWORKING BANDSAW

HVBS56M-M...414458M...1~230V,50Hz

PARTS LIST

Walter Meier (Tool) AG
Tämperlistr. 5
CH-8117 Fällanden
Switzerland
Phone +41 44 806 47 48
Fax +41 44 806 47 58
jetinfo.eu@waltermeier.com
www.jettools.com



P-414458M

2011-03

Breakdown for Arm Assembly

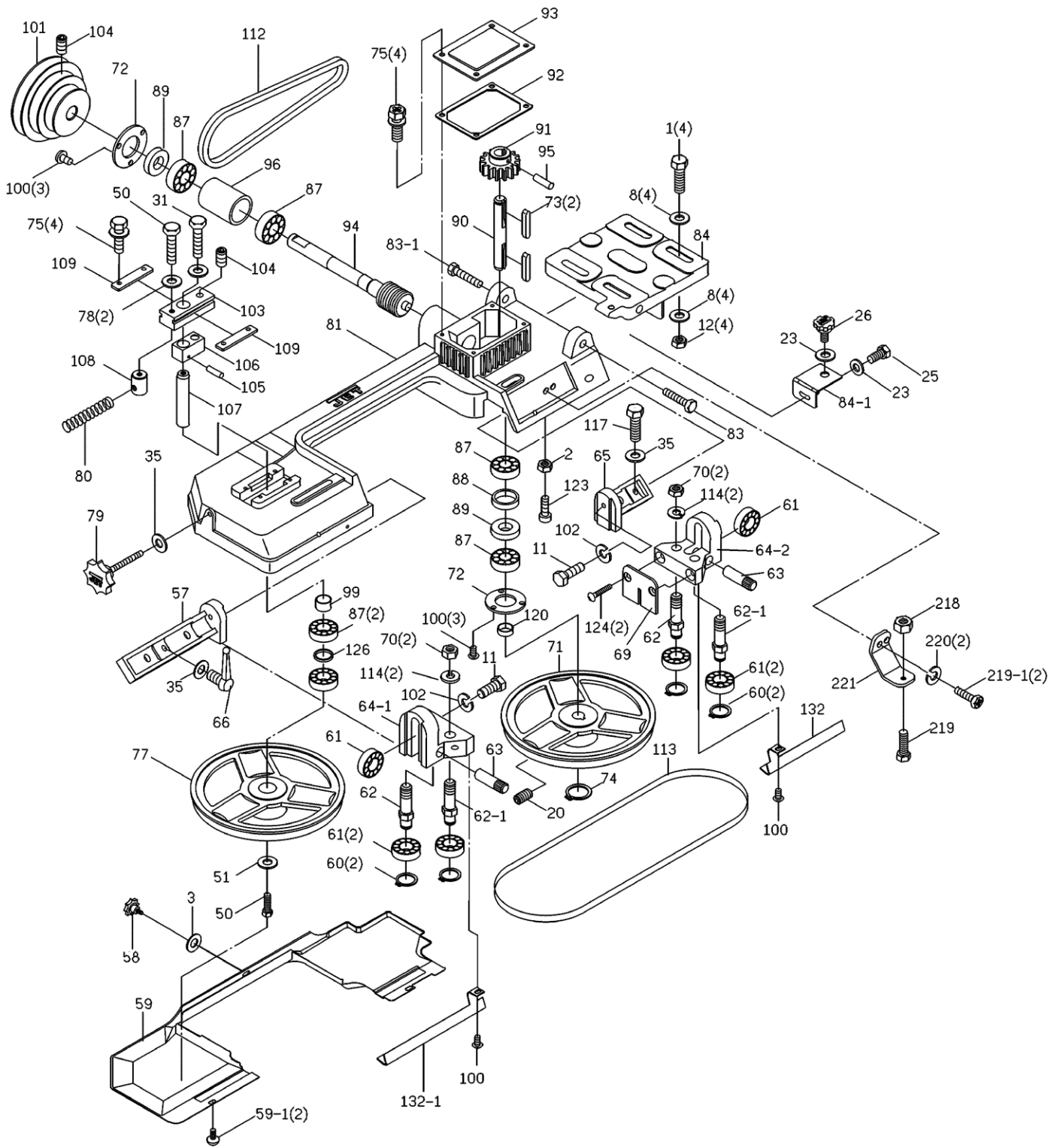

Breakdown for Bed Assembly

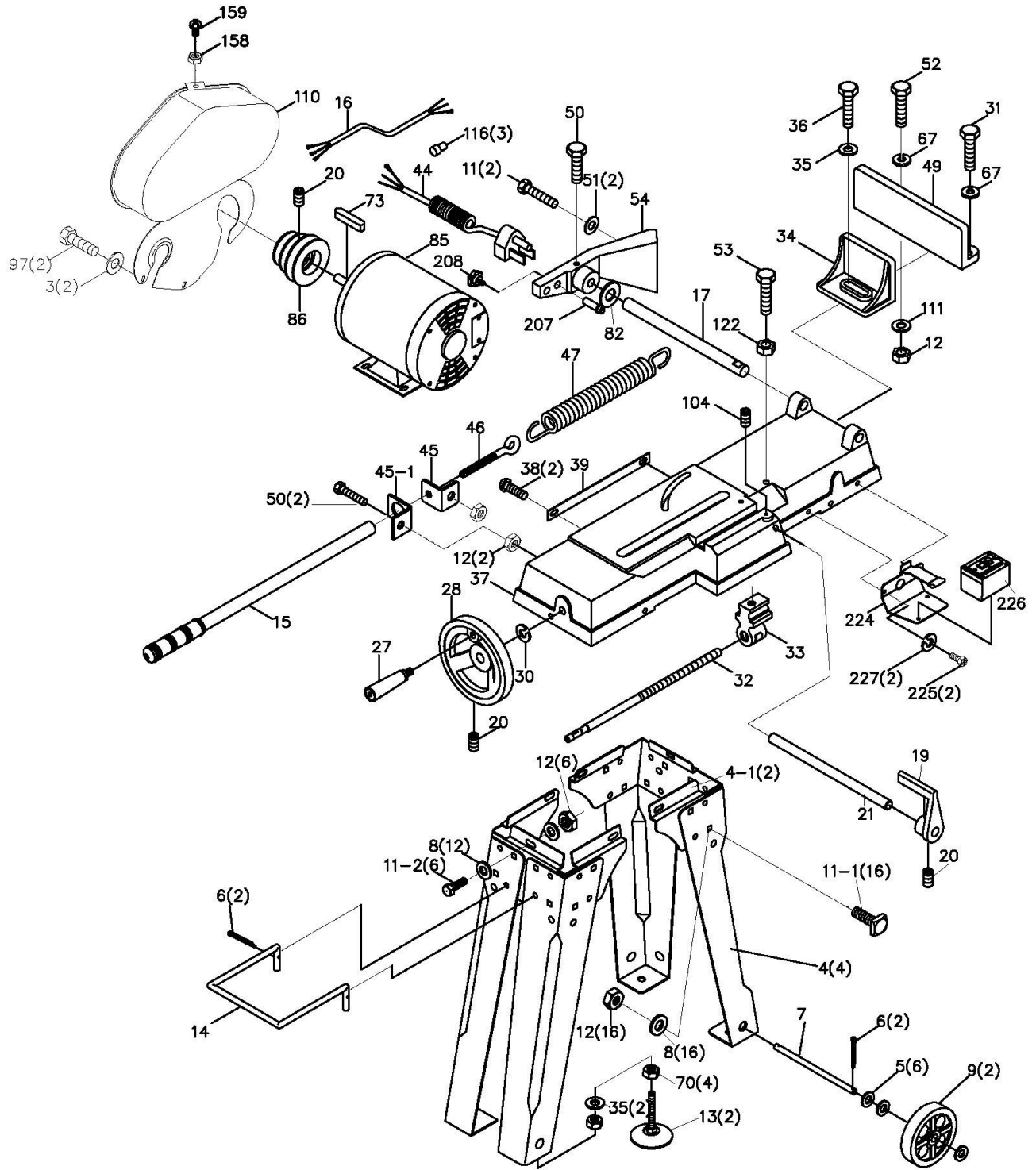

Parts List for HVBS-56M Band saw

Index No.	Part No.	Description	Size	Qty.
1	TS-0051031	Hex Cap Bolt	5/16"x3/4"	4
2	TS-0561011	Hex Nut	1/4"	1
3	TS-0680021	Flat Washer	1/4"	1
4	HVBS56M-04	Stand Leg		4
4-1	HVBS56M-04-1	Cross Brace		2
	HVBS56M-04A	Completely Stand Leg & Cross Brace Assembly (4, 4-1)		
5	HVBS56M-05	Washer		6
6	HVBS462-006	Cotter Pin	1/8"x1"	4
7	HVBS56M-07	Axle		1
8	TS-0680031	Flat Washer	5/16"	36
9	HVBS56M-09	Wheel		2
11	TS-0051051	Hex Cap Bolt	5/16"x1"	4
11-1	HVBS56M-11-1	Carriage Bolt	5/16"x3/4"	16
11-2	TS-0051051	Hex Cap Bolt	5/16"x1"	6
12	TS-0561021	Hex Nut	5/16"	27
13	HVBS56M-013	Adjustable Foot		2
14	HVBS462-014	Floor Stand Handle		1
15	HVBS462-015	Adjusting Rod		1
16	HVBS462-016E	Electric Cord		1
17	HVBS462-017	Pivoting Rod		1
19	HVBS462-019	Stock Stop		1
20	TS-0270021	Socket Set Screw	5/16"x5/16"	4
21	HVBS462-021	Stock Stop Rod		1
23	TS-0680031	Flat Washer	5/16"	2
25	TS-0051031	Hex Cap Bolt	5/16"x3/4"	1
26	HVBS56M-026E	Plum Knob		1
27	HVBS462-027	Wheel Handle		1
28	HVBS462-028	Hand Wheel		1
30	HVBS462-030	E-Ring	E10	1
31	TS-0051041	Hex Cap Bolt	5/16"x1"	2
32	HVBS462-032	Lead Screw		1
33	HVBS462-033	Vise Nut		1
34	HVBS462-034	Moveable Vise Plate		1
35	TS-0680041	Flat Washer	3/8"x1"	6
36	TS-0090061	Hex Cap Bolt	3/8"x1-1/4"	1
37	HVBS462-037E	Bed		1
38	HVBS462-038	Cross Round Head Screw	3/16"x3/8"	2
39	HVBS462-039	Scale		1
44	HVBS462-044E	Power Cable	H05RN-F,3Gx0.75mm	1
45	HVBS462-045	Nut Plate		1
45-1	HVBS56M-045-1	Spring Handle Bracket		1
46	HVBS462-046	Spring Adjusting Screw		1
47	HVBS462-047	Spring		1
49	HVBS462-049	Mitering Vise Plate		1
50	TS-0081031	Hex Cap Bolt	5/16"x3/4"	5
51	TS-0680031	Flat Washer	5/16"	3
52	TS-0081071	Hex Cap Bolt	5/16"x1-1/2"	1
53	TS-0091071	Hex Cap Screw	7/16"x2"	1
54	HVBS56M-054E	Pivot Bracket		1
57	HVBS56M-057	Adjustable Bracket Assembly LH		1

Index No.	Part No.	Description	Size	Qty.
58	HVBS462-058	Knob	1/4"	1
59	HVBS56M-059E	Blade Back Safety Cover		1
59-1	HVBS56M-059-1E	Pan Screw	1/4"x3/8"L	2
	HVBS56M-CLB/CE	Caution Label for Blade Back Cover (not shown)		1
60	HVBS462-060	C-Clip	S10	4
61	BB-6000ZZ	Ball Bearing	6000ZZ	6
62	HVBS462-062	Guide Pivot		2
	HVBS462-062A	Center Shaft Assembly (Includes: #60-62)		1
62-1	HVBS462-062-1	Centrifugal Guide Pivot		2
	HVBS462-062-1A	Eccentric Shaft Assembly (Includes: #60,61,62-1)		1
63	HVBS462-063	Bearing Shaft Pin		2
64-1	HVBS462-064-1	Blade Seat Left		1
64-2	HVBS462-064-2	Blade Seat Right		1
65	HVBS56M-065	Adjustable Bracket-Assembly RH		1
66	HVBS462-066	Lock Knob		1
67	TS-0720081	Lock Washer	5/16"	2
69	HVBS462-069	Bearing Guard		1
70	TS-0561031	Hex Nut	3/8"	4
70-1	HVBS56M-070-1	Hex Nut	3/8"	2
71	HVBS462-071	Blade Wheel Drive		1
72	HVBS462-072	Bearing Cover		2
73	HVBS462-073	Key	5x5x25	3
74	HVBS56M-074	C-Clip	S15	1
75	HVBS462-075	Hex Cap Bolt (w/Washer)	1/4"x1/2"	8
77	HVBS462-077	Idle Blade Wheel		1
78	TS-0680031	Flat Washer	5/16"	2
79	HVBS462-079	Blade Tension Knob	3/8"	1
80	HVBS462-080	Spring		1
81	HVBS56M-081	Saw Bow		1
82	HVBS56M-082	Washer		1
83	TS-0070031	Cap Screw	1/2"x1-1/2"	1
83-1	HVBS56M-83-1E	Cap Screw w/ Hole for Pan Screw	1/2"x1-1/2"	1
84	HVBS56M-084	Motor Mount Plate		1
84-1	HVBS56M-084-1	Tension Bracket		1
85	HVBS463-085E	Motor (080629795 and higher)	1/2HP/ 230V/50Hz	1
	HVBS56M-085EOL	Overload Protection (080629795 and higher)	4A	1
	HVBS462-085-01E	Capacitor Cover (not shown)		1
	HVBS462-085-02E	Capacitor (not shown)	200MFD 125VAC	1
	HVBS462-085-03E	Fan		1
	HVBS462-085-04E	Fan Cover		1
	HVBS56M-085-05E	Wiring connection cover (upper)(not show)		1
	HVBS56M-085-06E	Wiring connection cover (bottom)(not show)		1
	HVBS56M-085-07E	Motor terminal block(not show)		1
86	HVBS462-086	Motor Pulley		1
87	BB-6202ZZ	Ball Bearing	6202ZZ	6
88	HVBS462-088	Bearing Bushing		1
89	OS-15375	Oil Seal		2
90	HVBS462-090	Transmission Wheel Shaft		1
91	HVBS462-091	Worm Gear		1
92	HVBS462-092	Gear Box Gasket		1
93	HVBS462-093	Gear Box Cover		1
94	HVBS462-094	Worm Gear (w/Shaft)		1

Index No.	Part No.	Description	Size	Qty.
95	HVBS462-095	Spring Pin		1
96	HVBS462-096	Bearing Bushing		1
97	HVBS56M-097E	Pan Screw	1/4"x3/8"	3
99	HVBS462-099	Spacer		1
100	HVBS462-100	Flat Cross Head Screw	5/32"x3/8"	8
101	HVBS462-101	Worm Gear Pulley		1
102	TS-0720081	Lock Washer	5/16"	2
103	HVBS462-103	Blade Tension Sliding Plate		1
104	TS-0270051	Socket Set Screw	5/16"x1/2"	3
105	HVBS462-105	Spring Pin		1
106	HVBS462-106	Sliding Plate Draw Block		1
107	HVBS462-107	Blade Wheel Shaft		1
108	HVBS462-108	Shaft Block		1
109	HVBS462-109	Blade Tension Sliding Guide		2
110	HVBS462-110E	Motor Pulley Cover Assembly		1
	HVBS56M-CLC/CE	Caution Label for Pulley Cover (not shown)		1
111	TS-0680031	Flat Washer	5/16"	1
112	VB-A22	V-Belt	A22	1
113	414301	Blade		1
114	TS-0680041	Flat Washer	3/8"	4
116	HVBS463-170	Wire Plug		3
117	HVBS463-171	Hex Screw	3/8"x1-1/4"	1
120	HVBS462-120	Bushing		1
122	TS-0561041	Hex Nut	7/16"	1
123	TS-0050031	Cap Screw	1/4"x3/4"	1
124	HVBS463-124	Machine Screw	3/16"x3/4"	2
126	HVBS462-126	Bushing		1
132	HVBS462-132	Blade Guard-Right		1
132-1	HVBS462-132A	Blade Guard-Left		1
158	HVBS463-158	Hex. Nut	3/16"	1
159	HVBS463-159	Round Head Screw	3/16"x1/2	1
	HVBS56M-BS/CE	50HZ Blade Speed Label (not shown)		1
	HVBS56M-ID/CE	CE's I.D. Label (not shown)		1
	JM-56M	Stripe Decal (not shown)		1
207	HVBS56M-207E	Position Pin		1
208	HVBS56M-208E	Plum Handle		1
218	HVBS56M-218E	Hex Nut		1
219	HVBS56M-219E	Hex Cap Bolt		1
219-1	HVBS56M-219-1E	Hex Cross Cap Bolt	1/4" x 3/8"L	2
220	HVBS56M-220E	Washer		2
221	HVBS56M-221E	Switch Cut Off Base		1
224	HVBS56M-224E	Switch Base		1
225	HVBS56M-225E	Hex Cross Cap Bolt	1/4" x 3/8"L	2
226	HVBS56M-226E	CE Push Button Switch		1
227	HVBS56M-227E	Star Washer	3/16"	2

HVBS56M-M.....414458M.....1~230V,50Hz

	colour of strands	Litzenfarben	couleur des cordons
BK	black	schwarz	noir
WH	white	weiß	blanc
BU	blue	blau	bleu
YE	yellow	gelb	jaune
RD	red	rot	rouge
BN	brown	braun	brun
GY	grey	grau	gris
GNYE	green-yellow	grün-gelb	vert-jaune
OG	orange	orange	orange
VT	violet	violett	violet

	meaning of symbol	Bedeutung der Zeichen	interprétation
M	motor	Motor	moteur
S	switch	Schalter	interrupteur
C	condenser	Kondensator	condensateur
E	electronic unit	Elektronik Einheit	unité électronique
F	fuse	Sicherung	fusible
RS	reversing switch	Drehrichtungsschalter	commu. droite/gauche
CS	centrifugal switch	Fliehkraftschalter	déclencheur centrifuge
OL	overload cut-off	Überlastschuttschalter	déclencheur surcharge
LS	limit switch	Positionsendschalter	micro

