

# **J E T**

**JMD-18**

**JMD-18PF**

**METALWORKING Mill/Drill**

**350018M**

**350051M**

**230/50/1**

## **PARTS LIST**

**Walter Meier (Tool) AG**

Tämperlistrasse 5

CH-8117 Fällanden

Switzerland

Phone +41 44 806 47 48

Fax +41 44 806 47 58

[jetinfo.eu@waltermeier.com](mailto:jetinfo.eu@waltermeier.com)

[www.jettools.com](http://www.jettools.com)



P-350018M 350051M 2010/06/25

# Breakdown for the JMD-18, JMD-18PF CE Mill/Drill Transmission Assembly

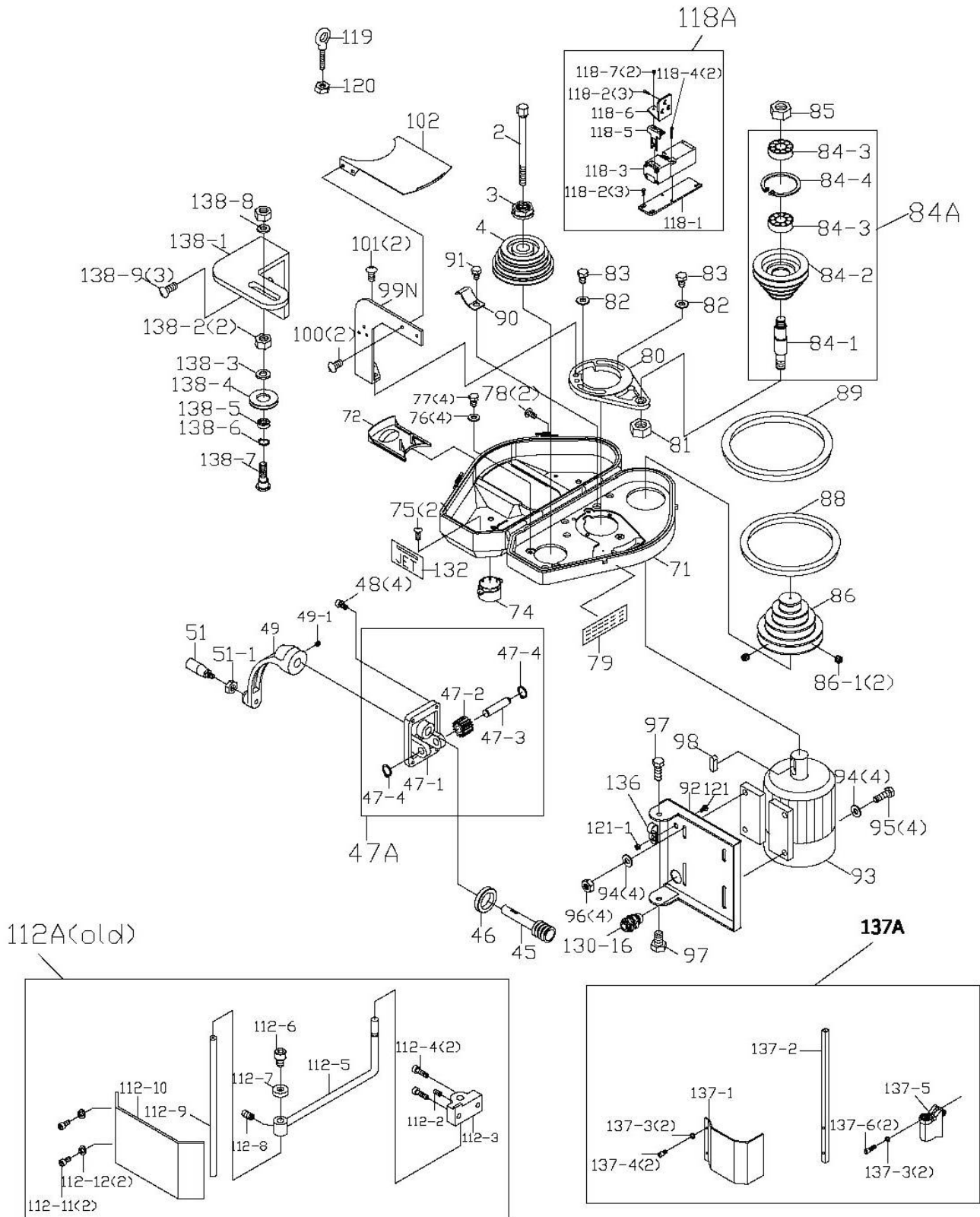

# Breakdown for the JMD-18 CE Mill/Drill Head Assembly

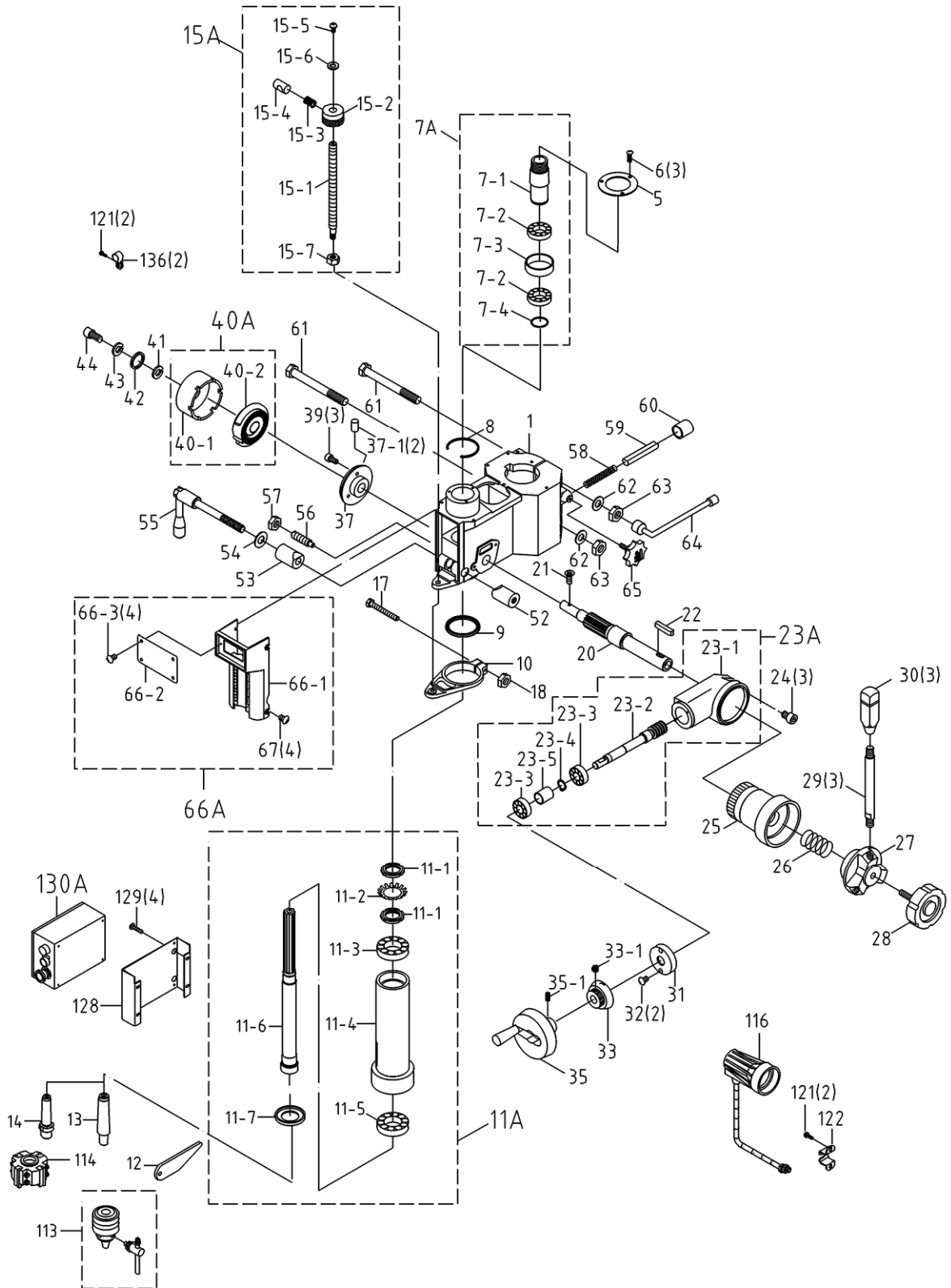

# Breakdown for the JMD-18PF CE Mill/Drill Head Assembly

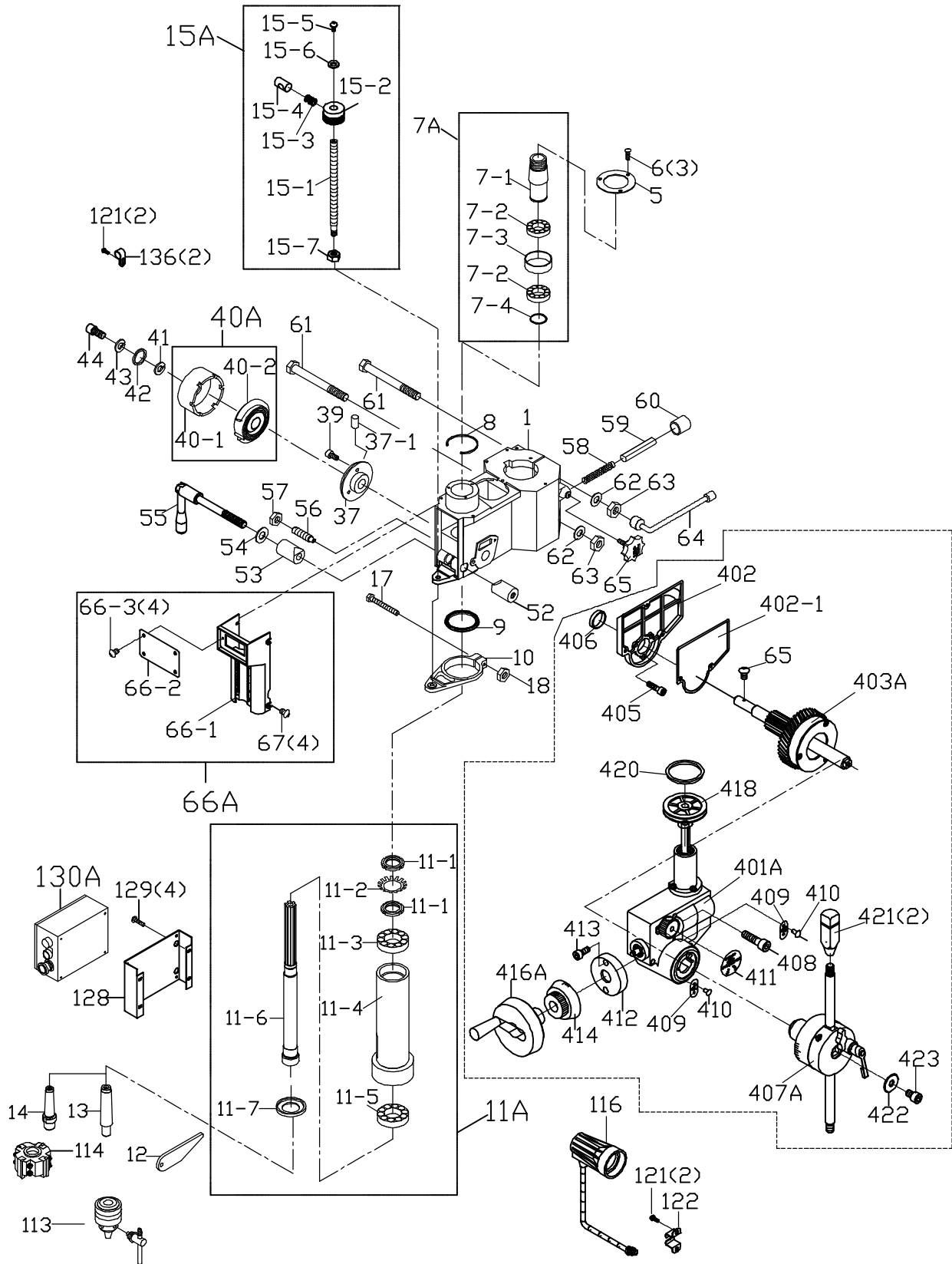

**Parts List for the JMD-18 ,JMD-18PF CE Mill/Drill  
Transmission & Head Assembly**

<b>Index No.</b>	<b>Part No.</b>	<b>Description</b>	<b>Size</b>	<b>Qty.</b>
1	JMD18N-001	Head Body		1
2	JMD18VS-001E	Drawbar , MT-3	M12	1
3	JMD18-002A	Spindle Lock Nut		1
4	JMD18-003A	Spindle Pulley		1
5	JMD18-005	Outer Bearing Plate	105x66	1
6	JMD18-133	Round Head Screw	1/4"x3/8"	3
7A	JMD18-006A	Spindle Taper Sleeve Assembly		1
7-1	JMD18-006	Spindle Taper Sleeve		1
7-2	BB-6009ZZ	Ball Bearing	6009ZZ	2
7-3	JMD18-008	Spacer	74x68	1
7-4	JMD18-023	Fixed Ring	2x4	1
8	JMD18-009	C-Retaining Ring	3x80	1
9	JMD18-012	Rubber Flange		1
10	JMD18N-010	Feed Base		1
11A	JMD18-014AE	Rack Sleeve Set		1
11-1	JMD18-014	Lock Nut		2
11-2	JMD18-137	Lock Washer		1
11-3	BB-30206	Taper Roller Bearing	30206	1
11-4	JMD18-016E	Rack Sleeve	MT3	1
11-5	BB-30207	Taper Roller Bearing	30207	1
11-6	JMD18-017E	Spindle Shaft	MT3	1
11-7	JMD18-019	Bearing Cap	MT3	1
12	JMD18-012E	Punch Key		1
13	JMD18-021E	Chuck Arbor	MT3, M12	1
14	JMD18-020E	Cutter Arbor	22mm, M12	1
15A	JMD18N-015A	Graduated Rod Assembly(only JMD-18)		1
15-1	JMD18N-15-1	Depth Scale Stud(only JMD-18)		1
15-2	JMD18N-15-2	Adjustable Stop(only JMD-18)		1
15-3	JMD18N-15-3	Spring(only JMD-18)		1
15-4	JMD18N-15-4	Push Button(only JMD-18)		1
15-5	JMD18N-15-5	Hex Socket Cap Screw(only JMD-18)	M5x8	1
15-6	JMD18N-15-6	Washer(only JMD-18)	M5x15xt1.2	1
15-7	JMD18N-15-7	Hex Nut(only JMD-18)	3/8"	1
17	TS-0050091	Hex Head Screw	1/4"x2"	1
18	TS-0561011	Hex Nut	1/4"	1
20	JMD18-106	Pinion Shaft		1
21	JMD18-188	Flat Cross Head Screw	3/16"x3/8"	1
22	JMD18-142	Key	7x7x20mm	1
23A	JMD18N-023A	Gear Housing Assembly		1
23-1	JMD18N-023	Gear Housing		1
23-2	JMD18-047	Worm Shaft		1
23-3	BB-6202Z	Ball Bearing	6202ZZ	2
23-4	JMD18-148	C-ring	15	1
23-5	JMD18-035	Bearing Spacer	34x27.5	1
24	TS-0208021	Hex Socket Cap Screw	5/16"x1/2"	3
25	JMD18-107	Worm Gear		1
26	JMD18-115	Spring		1
27	JMD18-110	Hub		1
28	JMD18-038	Knob		1
29	JMD18N-029	Handle Rod		3
30	JMD18N-030	Knob		3
31	JMD18-045	Flange		1
32	JMD18-047	Round Head Screw	3/16"x3/8"	2
33	JMD18N-033E	Micro Adjusting Indicator		1
33-1	TS-0267021	Set Screw	1/4"x1/4"	1
35	JMD18N-035A	Feed Handle Wheel Assembly		1

Index No.	Part No.	Description	Size	Qty.
37	JMD18-105	Spring Base		1
37-1	JMD18-140	Spring Pin		2
39	JMD18-139	Round Head Screw	3/16"x3/4"	3
40A	JMD18-103A	Spring Cover Assembly		1
40-1	JMD18-103	Spring Cover		1
40-2	JMD18-104	Spring		1
41	JMD18-187	Washer	1/4"x1"	1
42	TS-0680021	Washer	1/4"	1
43	JMD18-187	Lock Washer	1/4"x1"	1
44	JMD18-085	Knob	1/4"	1
45	JMD18-059	Worm Shaft		1
46	JMD18-114	Bushing		1
47A	JMD18-101A	Head Raise Bracket Assembly		1
47-1	JMD18-101	Head Raise Bracket		1
47-2	JMD18-060	Worm Gear		1
47-3	JMD18-061	Shaft	9/16"	1
47-4	JMD18-154	C-ring	S14	2
48	TS-0207061	Hex Socket Cap Screw	1/4"x1"	4
49	JMD18-058E	Head Handle	165L	1
49-1	TS-0271061	Set Screw	3/8"x5/8"	1
51	JMD18-022	Handle		1
51-1	TS-0561031	Hex Nut	3/8"	1
52	JMD18-026	Fixed Collar (Thread)		1
53	JMD18-025	Fixed Collar		1
54	JMD18N-054	Washer	1/2"x7/8"	1
55	JMD18-024E	Handle Rod	165L	1
56	JMD18-027	Screw Key	3/8"	1
57	TS-0561031	Hex Nut	3/8"	1
58	JMD18-062	Spring		1
59	JMD18-063	Pin		1
60	JMD18-079	Rubber Collar		1
61	JMD18-052	Bolt	5/8"x6"	2
62	TS-0680081	Washer	5/8"	2
63	TS-0561071	Hex Nut	5/8"	2
64	JMD18-050E	Lock Handle		1
65	JMD18N-065	Knob (w/ JET logo)		1
66A	JMD18N-066A	Front Cover Plate Assembly		1
66-1	JMD18N-066-1	Front Cover Plate		1
66-2	JMD18-066-2E	Dust Plate		1
	JMD18-WLE	Warning Label for CE (not shown)		1
66-3	TS-1531012	Pan Head Screw	M3x6	4
67	JMD18N-067	Round Head Screw	M6x12	4
71	JMD18-069	Poly Belt Cover		1
72	JMD18-069A	Pulley Cover		1
74	JMD18-069-1	Spindle Cover		1
75	JMD18-069-3	Machine Screw	4mm	2
76	TS-0680032	Flat Washer	5/16"	4
77	TS-0051011	Hex Head Bolt	5/16"x1/2"	4
78	JMD18-078E	Pan Head Screw	M4x25	2
79	JMD18-SCE	Spindle Speed Chart		1
80	JMD18N-080	Pulley Base		1
81	TS-0561071	Hex Nut	5/8"	1
82	TS-0680031	Washer	5/16"	3
83	TS-0051071	Hex Head Bolt	5/16"x1-1/2"	2
84A	JMD18-075A	Inter Pulley Assembly		1
84-1	JMD18-075	Inter Pulley Shaft		1
84-2	JMD18-073	Inter Pulley		1
84-3	BB-6204Z	Ball Bearing	6204ZZ	2
84-4	JMD18-010	C-ring	2x52	1
85	TS-0561071	Hex Nut	5/8"	1

Index No.	Part No.	Description	Size	Qty.
86	JMD18-070	Motor Pulley		1
86-1	TS-0270021	Set Screw	5/16"x5/16"	2
88	VB-B33	V-Belt	B33	1
89	VB-B42	V-Belt	B42	1
90	JMD18-077	Wire Relief Retainer		1
91	TS-0051011	Hex Head Screw	5/16"x1/2"	1
92	JMD18-066E	Motor Mount Plate		1
93	JMD18-067E	Motor	2HP/230V/1PH	1
	JMD18-MLE	Motor Label for CE (not shown)		1
94	TS-0680031	Flat Washer	5/16"	8
95	TS-0051051	Hex Head Bolt	5/16"x1"	4
96	TS-0561021	Hex Nut	5/16"	4
97	TS-0061011	Hex Head Bolt	7/16"x3/4"	2
98	JMD18-159	Key	7x7x37mm	1
99	JMD18-99E	Guard Bracket		1
99N	JMD18-99NE	Guard Bracket		1
100	JMD18-100E	Pan Head Screw	M5x8L	2
101	TS-1534042	Pan Head Screw	M6x12	2
102	JMD18-102E	Protective Plate		1
112A	JMD18-112AE	Chuck Guard Assembly (#112-2~#112-12,S/N:9062468 higher )		1
112-2	TS-1522031	Set Screw	M5x10	1
112-3	JMD18-112-3E	Rotary Supporting Base		1
112-4	TS-1504051	Socket Head Cap Screw	M8x25	2
112-5	JMD18-112-5E	Rotary Shaft		1
112-6	JMD18-112-6E	Socket Head Cap Screw	M4x5	1
112-7	JMD18-112-7E	Bushing		1
112-8	TS-1523021	Socket Set Screw	M6x8	1
112-9	JMD18-112-9E	Chuck Guard Supporting Rod		1
112-10	JMD18-112-10E	Chuck Guard		1
112-11	TS-1502041	Socket Head Cap Screw	M5x16	2
112-12	TS-1551031	Lock Washer	M5	2
113	JMD18-113E	Drill Chuck w/ Chuck Key	13mm, B16	1
114	JMD18-086E	Milling Cutter	22mm	1
115	JMD18-115E	Power Cord	H07RN-Fx1.5mm <sup>2</sup>	1
116	JMD18N-116E	Lamp Assembly for CE	24V, 20W	1
118A	JMD18-118AE	Micro Switch Bracket Set (#118-1~#118-7)		1
118-1	JMD18-118-1E	Micro Switch Bracket		1
118-2	JMD18-118-2E	Machine Screw	M4x12L	6
118-3	JMD18-118-3E	Limit Switch		1
118-4	JMD18-118-4E	Socket Head Cap Screw	#8UNFx1"L	2
118-5	JMD18-118-5E	Limit Switch Plate		1
118-6	JMD18-118-6E	Micro Switch Bracket		1
118-7	JMD18-118-7E	Pan Head Screw	#8UNFx1/4"	2
119	JMD18N-119E	Lifting Hook	M10x33.5L	1
120	TS-1540071	Hex Nut	M10	1
121	JMD18-121E	Pan Head Screw	M5x8	5
121-1	TS-1540031	Hex Nut	M5	1
122	JMD18-122E	Lamp Bracket		1
128	JMD18-128E	Switch Plate(Date:0409 and lower)		1
128	JMD18-128EN	Switch Plate( s/no.9062468and higher)		1
129	TS-122032	Pan Head Machine Screw	M5x8	4
130	JMD18-130E	Electrical Box Assembly		1
132	JMD15-JL	JET logo		1
136	JMD18-136E	Rubber Collar		3
	JMD18-IDE	I.D. Label for CE (not shown)		1
	JMD18-SCE	Speed Chart for CE (not shown)		1
	JMD18-AP	Accessory Package (not shown) *		1
	JMD18-36701	Capacitor (not shown)	300MFD, 250VAC	1
	BD1325R-X02	Centrifugal Switch (not shown)		1
	JMD18-MF	Motor Fan (not shown)		1

<b>Index No.</b>	<b>Part No.</b>	<b>Description</b>	<b>Size</b>	<b>Qty.</b>
.....	JMD18-MFC	Motor Fan Cover (not shown)		1
.....	JMD18-303	Thermal Relay (not shown)	15A, 220V	1
137A ..	JMD18-137A	Chuck Guard Assembly (S/N:9062468 higher)		1
137-1 ..	JMD18-137-1	Chuck Guard		1
137-2 ..	JMD18-137-2	Chuck Guard Supporting Rod		1
137-3 ..	JMD18-137-3	Spring Washer	M5	4
137-4 ..	JMD18-137-4	Hex. Socket Head Screw	M5x10L	2
137-5 ..	JMD18-137-5	Rotary Supporting Base		1
137-6 ..	JMD18-137-6	Hex. Socket Head Screw	M5x15L	2
138.....	JMD18-138	idle pulley Assembly (S/N:9062468 higher)		1
138-1 ..	JMD18-138-1	Bracket(		1
138-2 ..	JMD18-138-2	Hex. Nut	M8	2
138-3 ..	JMD18-138-3	Washer	•8x•16x3.5t	1
138-4 ..	JMD18-138-4	Spindle Pulley		1
138-5 ..	JMD18-138-5	6001ZZ		1
138-6 ..	JMD18-138-6	C-Retainer Ring	R28	1
138-7 ..	JMD18-138-7	Shaft		1
138-8 ..	JMD18-138-8	Spring Washer	M8	1
138-9 ..	JMD18-138-9	Cross Round Head Screw	M5-0.8P*16L	3

**I Contents of the Accessory Package:**

<b>Index No.</b>	<b>Part No.</b>	<b>Description</b>	<b>Size</b>	<b>Qty.</b>
.....	JMD18-020E	Cutter Arbor	22mm	1
.....	JMD18-022	Handle		4
.....	JMD18-039	Handle Rod		3
.....	JMD18-040	Knob		2
.....	JMD18-050	Lock Handle		1
.....	561704E	Drill Chuck w/ Chuck Key	MT-3/B-16	1
.....	JMD18-086E	Cutter	22mm	1
.....	JMD18-021E	Chuck Arbor (Installed)	MT-3/B-16	1
.....	JMD18-012E	Punch Key		1
.....	365534	Angle Vise		1
.....	JMD18-058E	Head Handle		1
.....	JMD18-201	Wheel		3
.....	TS-152704	Hex Wrench	3mm	1
.....	TS-152705	Hex Wrench	4mm	1
.....	TS-152706	Hex Wrench	5mm	1
.....	TS-1505031	Socket Head Cap Screw	M10x25	1
.....	TS-1550071	Flat Washer	M10	1
.....	365534-01E	Hardware Package(Bolt, Nut,and Washer)	M12	2
.....	JMD18N-119E	Lifting Hook	M10x33.5	1
.....	MP-007	Touch Up Paint		1



# Breakdown for the JMD-18PF CE Mill/Drill Power-Down Feed Assembly

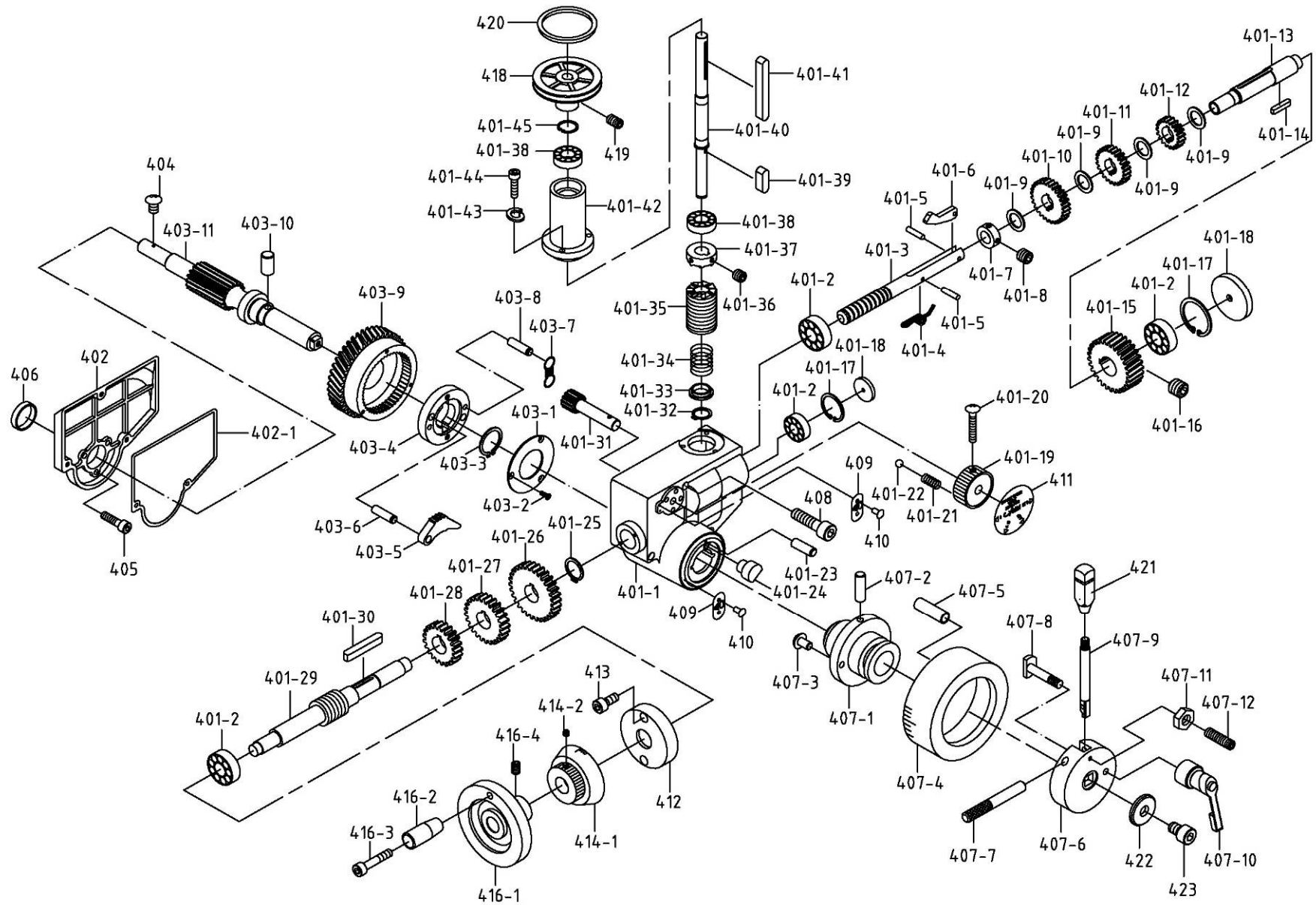

**Parts List for the JMD-18PF CE Mill/Drill  
Power-Down Feed Assembly**

<b>Index No.</b>	<b>Part No.</b>	<b>Description</b>	<b>Size</b>	<b>Qty.</b>
401A	291022AS	Gear Box Assembly (#401-1~#402-1)		1
401-1	291022A	Gear Box		1
401-2	BB-6003ZZ	Bearing	6003ZZ	4
401-3	2450082A	Change Gear Lever		1
401-4	2450084B	Tension Spring		1
401-5	JMD18PFN-360	Pin		2
401-6	2450083A	Stop		1
401-7	2450089A	Collar		1
401-8	TS-1523011	Set Screw	M6x6	2
401-9	2450074A	Spacer		4
401-10	2450072A	Gear		1
401-11	2450071A	Gear		1
401-12	2450070A	Gear		1
401-13	291026A	Shaft		1
401-14	JMD18PFN-269	Key	5x5x25	1
401-15	291047	Worm Gear		1
401-16	TS-1523011	Set Screw	M6x6	2
401-17	JMD18PFN-282	C-Ring	R35	2
401-18	2450014	Cover		2
401-19	2450079	Speed Knob		1
401-20	JMD18PFN-303	Round Head Screw	M4x25	1
401-21	290089	Spring		1
401-22	SB-5/16	Steel Ball	5/16"	1
401-23	2450051	Pin		1
401-24	2450020	Release Block		1
401-25	JMD18PFN-373	C-Ring	S19	1
401-26	2450077A	Gear		1
401-27	2450076A	Gear		1
401-28	2450075A	Gear		1
401-29	291028A	Transmission Worm		1
401-30	JMD18PFN-358	Key	5x5x32	1
401-31	291027A	Pinion		1
401-32	JMD18PFN-369	C-ring	S15	1
401-33	2450057	Bushing		1
401-34	2450054	Spring		1
401-35	291046	Worm Shaft		1
401-36	TS-1523011	Set Screw	M6x6	2
401-37	291050	Clutch Block		1
401-38	BB-6003ZZ	Ball Bearing		2
401-39	JMD18PFN-262	Key	5x5x10	1
401-40	291023A	Transmission Shaft		1
401-41	JMD18PFN-389	Key	5x5x45	1
401-42	291024A	Bearing Housing		1
401-43	TS-0720071	Lock Washer	1/4"	3
401-44	TS-0207041	Hex Socket Cap Screw	1/4"x3/4"	3
401-45	JMD18PFN-255	C-Ring	S17	1
402	291032A	Base		1
402-1	JMD18PFN-402-1	Greaseproof paper		1
403A	291029AS	Worm Gear Assembly (#403-1~#403-11)		1
403-1	2450048	Worm Gear Cover		1
403-2	JMD18PFN-346	Flat Cross Head Screw	M4x4	3
403-3	JMD18PFN-320	C-Ring	S25	1
403-4	2450024	Clutch Gear Case		1
403-5	2450026	Clutch Key		2
403-6	2450025	Clutch Key Pin		2
403-7	2450028	Spring		2

Index No.	Part No.	Description	Size	Qty.
403-8	2450027	Spring Pin		2
403-9	2450023	Worm Gear		1
403-10	2450022	Key		2
403-11	291029A	Pinion Shaft		1
404	JMD18PFN-250	Flat Head Screw	3/16"x3/8"	1
405	TS-0208061	Hex Socket Cap Screw	5/16"x1-1/4"	3
406	291049	Bearing Spacer		1
407A	291030AS	Clutch Bushing Assembly (#407-1~#407-12)		1
407-1	291030A	Clutch Bushing		1
407-2	2450030	Bushing Pin		1
407-3	2450031	Bushing Stop		1
407-4	2540032E	Scale Base		1
407-5	JMD18PFN-326	Pin		1
407-6	2450037	Hub		1
407-7	2450039	Pin		2
407-8	2450033	Scale Base Set Screw		1
407-9	2450038	Handle Rod		2
407-10	2450063	Graduated Base Handle		1
407-11	H02050	Hex Nut	5/16"	1
407-12	JMD18PFN-407-12	Set Screw	5/16"x3/4"	1
408	JMD18PFN-350	Hex Socket Cap Screw	5/16"x3-1/2"	3
409	2450060	Pointer		2
410	JMD18PFN-309	Rivet		4
411	JMD18PFN-354E	Speed Scale		1
412	6145	Worm Cover		1
413	JMD18PFN-376	Socket Head Cap Screw	3/16"x3/8"	2
414-1	291051E	Micro Adjusting Indicator		1
414-2	TS-0267031	Set Screw	1/4"x5/16"	1
416A	6142-2S	Fine Down Wheel Assembly (#416-1~#416-4)		1
416-1	6142-2	Hand Wheel		1
416-2	6580	Handle		1
416-3	6581	Handle Screw		1
416-4	TS-0270021	Set Screw	5/16"x5/16"	1
418	290110	Sub-Pulley		1
419	TS-0267031	Set Screw	1/4"x5/16"	1
420	JMD18PF-114	Belt		1
421	290086	Knob		2
422	2450040	Washer	M8	1
423	TS-1504031	Hex Socket Cap Screw	M8x16	1
	JMD18PF-PFAE	Power Down Feed Assembly Complete (#401~#423)		1

## Breakdown for the JMD-18 ,JMD-18PF CE Mill/Drill Table, Base, and Column Assembly

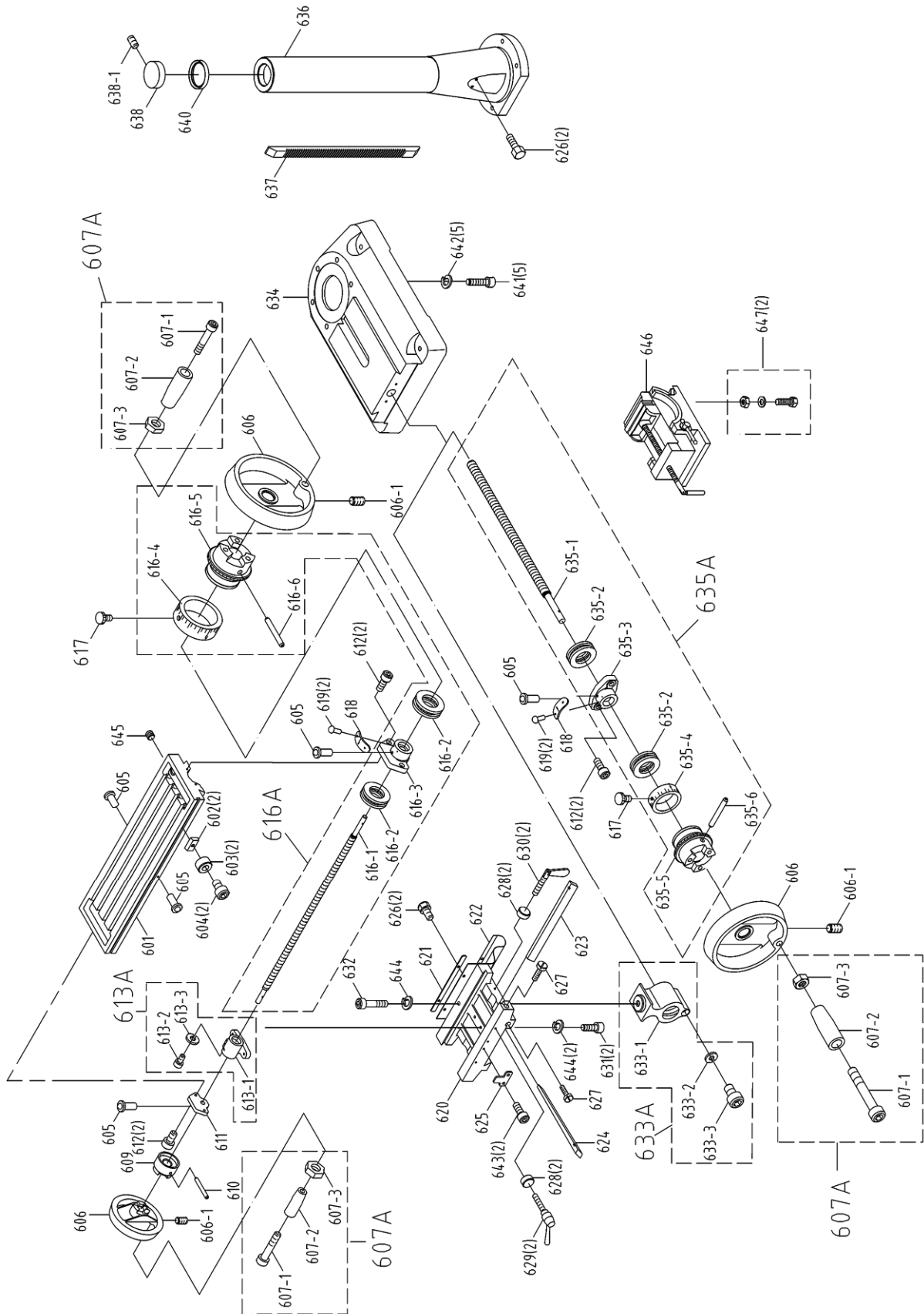

**Parts List for the JMD-18,JMD-18PF CE Mill/Drill  
Table, Base, and Column Assembly**

<b>Index No.</b>	<b>Part No.</b>	<b>Description</b>	<b>Size</b>	<b>Qty.</b>
601.....	JMD18-228.....	Table.....	31L.....	1
602.....	JMD18-229.....	Fixed Block.....		2
603.....	JMD18-230.....	Movable Ring.....		2
604.....	TS-0207021.....	Hex Socket Head Screw.....	1/4"x1/2"	2
605.....	JMD18-368.....	Oil Ball.....	1/4"	5
606.....	JMD18-201.....	Table Handle Wheel.....		3
606-1 .....	TS-0267041.....	Set Screw.....	1/4"x3/8"	3
607A .....	JMD18-201A.....	Handle Assembly.....		3
607-1 .....	JMD18-201-1.....	Hex Socket Head Screw.....	3/8"x16UNC	3
607-2 .....	JMD18-201-2.....	Knob.....		3
607-3 .....	JMD18-201-3.....	Hex Nut.....	3/8"	3
609.....	JMD18-220.....	Table Clutch.....		1
610.....	JMD18-366.....	Pin.....	5x38	1
611.....	JMD18-222.....	Left Flange.....		1
612.....	TS-0208062.....	Hex Socket Head Screw.....	5/16"x1"	6
613A .....	JMD18-223AE.....	Table Nut Assembly (#613-1~#613-3).....		1
613-1 .....	JMD18-223E.....	Table Nut.....	TM23.7xP2.5.....	1
613-2 .....	TS-1502041.....	Cheese Head Mach Screw.....	M5x16.....	1
613-3 .....	TS-1550031.....	Flat Washer.....	M5.....	1
616A .....	JMD18-224AE.....	Table Screw Assembly (#616-1~#616-6).....		1
616-1 .....	JMD18-224E.....	Table Lead Screw.....	TM23.7*P2.5.....	1
616-2 .....	BB-51103.....	Thrust Bearing.....	51103.....	2
616-3 .....	JMD18-226.....	Right Flange.....		1
616-4 .....	JMD18-202-1E.....	Graduated Dial.....		1
616-5 .....	JMD18-202.....	Dial Clutch.....		1
616-6 .....	JMD18-366.....	Pin.....	5x38L.....	1
617.....	JMD18N-617.....	Link Screw.....		2
618.....	JMD18-121.....	Link Plate.....		2
619.....	JMD18-204-2.....	Rivet.....	2mm.....	4
620.....	JMD18-216.....	Center Base.....	31L.....	1
621.....	JMD18-219.....	Antidust Plate.....		1
622.....	JMD18-217.....	Antidust Plate Assembly.....		1
623.....	JMD18-227.....	Gib Strip.....	31L.....	1
624.....	JMD18-207.....	Gib Strip.....	31L.....	1
625.....	JMD18-214.....	Fixed Block.....		1
626.....	TS-0051011.....	Hex Head Screw.....	5/16"x1/2"	4
627.....	JMD18-212.....	Gib Strip Bolt.....		2
628.....	JMD18N-628.....	Bushing.....		4
629.....	JMD18-213-1.....	Locking Handle.....		2
630.....	JMD18-213.....	Leaf Screw.....		2
631.....	TS-0208061.....	Hex Socket Head Screw.....	5/16"x1"	2
632.....	TS-0051101.....	Hex Socket Head Screw.....	5/16"x2-1/4"	1
633A .....	JMD18-215AE.....	ACME Nut Assembly (#633-1~#633-3).....		1
633-1 .....	JMD18-215E.....	ACME Nut.....	TM23.7*P2.5.....	1
633-2 .....	TS-1550031.....	Flat Washer.....	M5.....	1
633-3 .....	TS-1502041.....	Hex Socket Head Screw.....	M5x16.....	1
634.....	JMD18N-634.....	Base.....		1
635A .....	JMD18-205AE.....	ACME Nut Assembly (#635-1~#635-6).....		1
635-1 .....	JMD18-205E.....	Cross Lead Screw.....	TM23.5*P2.5.....	1
635-2 .....	BB-51103.....	Thrust Bearing.....	51103.....	2
635-3 .....	JMD18-204.....	Square Flange.....		1
635-4 .....	JMD18-202-1E.....	Graduated Dial.....		1
635-5 .....	JMD18-202.....	Dial Clutch.....		1
635-6 .....	JMD18-366.....	Pin.....	5x38mm.....	1
636.....	JMD18N-636.....	Column Base.....		1
637.....	JMD18N-637.....	Rack.....	600.5L.....	1

<b>Index No.</b>	<b>Part No.</b>	<b>Description</b>	<b>Size</b>	<b>Qty.</b>
638.....	JMD18-211.....	Column Cap.....		1
638-1 .....	TS-0270021.....	Set Screw.....	5/16"x5/16".....	1
640.....	JMD18-209.....	Column Flange Ring.....		1
641.....	JMD18N-641 .....	Hex Socket Cap Bolt .....	5/8"x2-1/2".....	5
642.....	TS-0720131.....	Lock Washer .....	5/8".....	5
643.....	TS-0208022.....	Socket Head Cap Screw.....	5/16"x1/2".....	2
644.....	JMD18N-644 .....	Lock Washer .....	5/16".....	3
645.....	JMD18N-645 .....	Plug .....	PT1/4"x3/8".....	1
646.....	365534 .....	Vise.....		1
647.....	365534-01E.....	Hardware Package(Bolt, Nut, and Washer).....	M12.....	2

## Breakdown for the JMD-18, JMD-18PF CE Mill/Drill Electrical Box Assembly

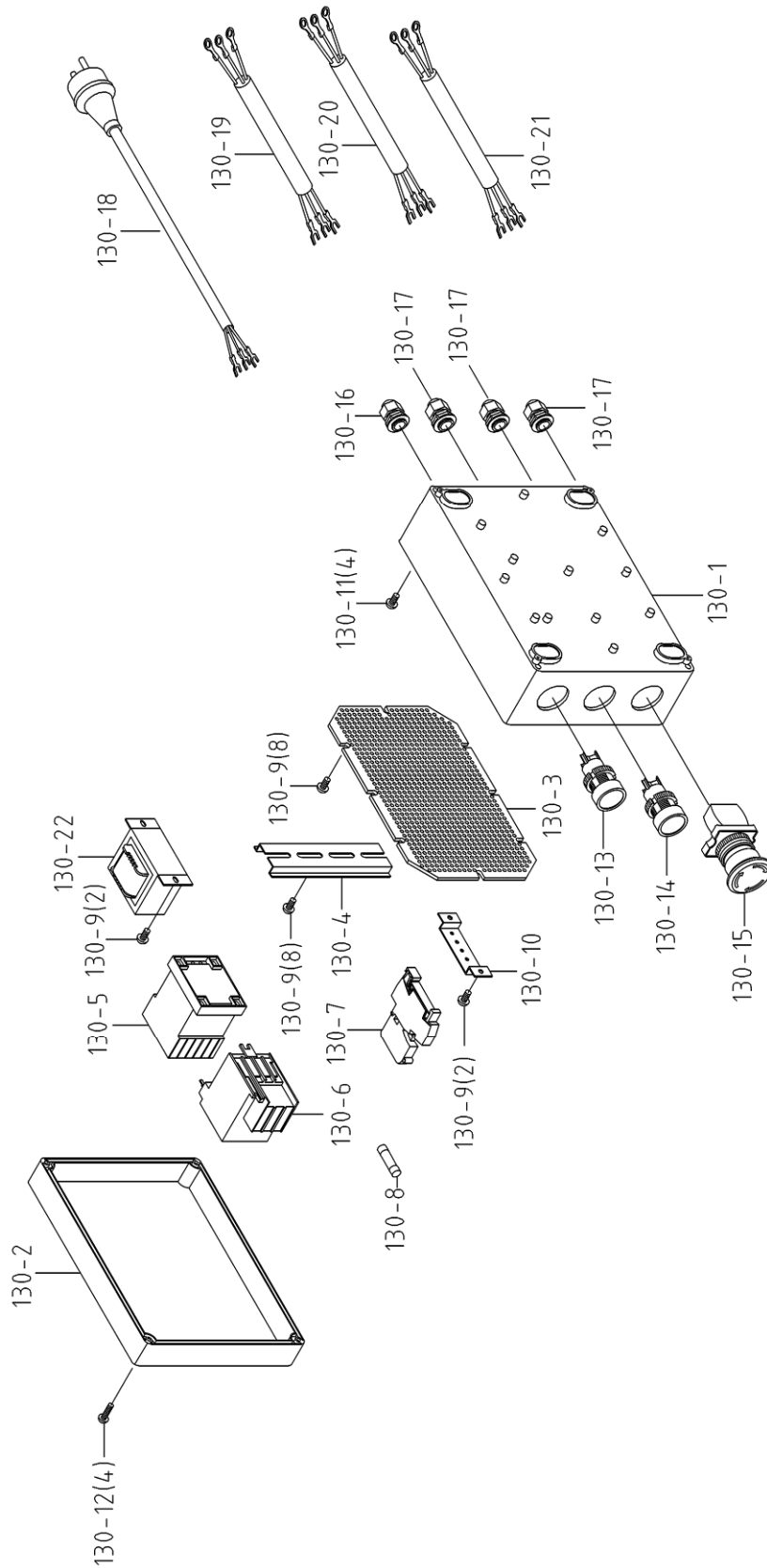

**Parts List for the JMD-18, JMD-18PF CE Mill/Drill  
Electrical Box Assembly**

<b>Index No.</b>	<b>Part No.</b>	<b>Description</b>	<b>Size</b>	<b>Qty.</b>
130-1	JMD18-130-1E	Box Base		1
130-2	JMD18-130-2E	Box Cover		1
130-3	JMD18-130-3E	Base Plate		1
130-4	JMD18-130-4E	Bracket		1
130-5	JMD18-130-5E	Contactora		1
130-6	JMD18-130-6E	Overload		1
130-7	JMD18-130-7E	Fuse Bracket		1
130-8	JMD18-130-8E	Fuse	2A	1
130-9	JMD18-130-9E	Pan Head Screw	#8 x 1/4"L	20
130-10	JMD18-130-10E	Ground Plate		1
130-11	JMD18-130-11E	Pan Head Screw	3/16" x 5/16"L	4
130-12	TS-1532042	Pan Head Screw	M4 x 12L	4
130-13	JMD18-130-13E	Start Push Button		1
130-14	JMD18-130-14E	Stop Push Button		1
130-15	JMD18-130-15E	Emergency Stop Button		1
130-16	JMD18-130-16E	Wire Plug	PG13.5	2
130-17	JMD18-130-17E	Wire Plug	PG11	3
130-18	JMD18-130-18E	Power Cable w/ Plug	H07RN-F, 3G1.5mm <sup>2</sup>	1
130-19	JMD18-130-19E	Motor Cable	H05VV-F, 3G1.5mm <sup>2</sup>	1
130-20	JMD18-130-20E	Limit Switch Cable	H05VV-F, 2G0.75mm <sup>2</sup>	1
130-21	JMD18-130-21E	Light Cable	H05VV-F, 2G0.75mm <sup>2</sup>	1
130-22	JMD18-130-22E	Transformer	20VA	1



**JMD-18      JMD-18PF**  
**350018M    350051M**

**230/50/1**

	colour of strands	Litzenfarben	couleur des cordons
BK	black	schwarz	noir
WH	white	weiß	blanc
BU	blue	blau	bleu
YE	yellow	gelb	jaune
RD	red	rot	rouge
BN	brown	braun	brun
GY	grey	grau	gris
GNYE	green-yellow	grün-gelb	vert-jaune
OG	orange	orange	orange
VT	violet	violett	violet

	meaning of symbol	Bedeutung der Zeichen	interprétation
M	main motor	Hauptmotor	moteur principal
L	work lamp	Maschinenleuchte	lampe
S0	work lamp switch	Maschinenleuchte	lampe
S1	emergency stop switch	Not-Aus Schalter	arrêt d'urgence
S2	start switch	Ein-Schalter	bouton marche
S3	off switch	Aus-Schalter	bouton arrêt
KM	contactor for main motor	Hauptschütz	contacteur moteur
C	condenser	Kondensator	condensateur
E	electronic unit	Elektronik Einheit	unité électronique
F	fuse	Sicherung	fusible
RS	reversing switch	Drehrichtungsschalter	commu. droite/gauche
CS	centrifugal switch	Fliehkraftschalter	déclencheur centrifuge
OL	overload cut-off	Überlastschuttschalter	déclencheur surcharge
LS,LS1	limit switch	Positionsendschalter	micro
TR	transformer	Transformator	transformateur

