

JET

JML-1014I

MINI LATHE

708375M

230/50/1

PARTS LIST

Walter Meier (Tool) AG

Tämperlistrasse 5

CH-8117 Fällanden

Switzerland

Phone +41 44 806 47 48

Fax +41 44 806 47 58

jetinfo.eu@waltermeier.com

www.jettools.com



P-708375M 2010/06/25

Lathe Assembly

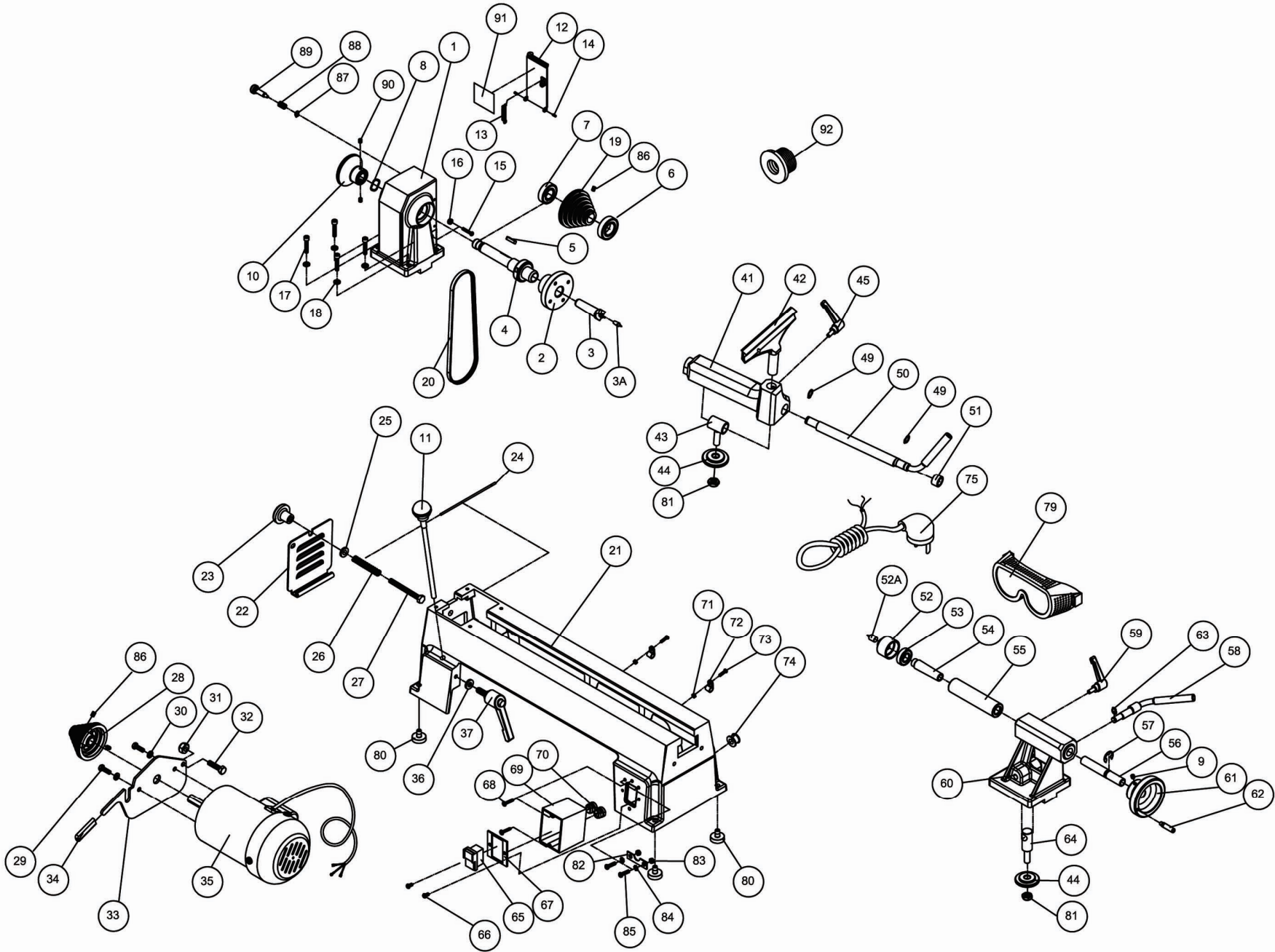

Parts List for the JML-1014I Wood Lathe

Index No.	Part No.	Description	Size	Qty.
1	JML1014-101	Headstock		1
2	JML-2	Faceplate	3"	1
3	JML-3	Spur Center	MT2	1
	JML-3A	Center Point Spur Center		1
4	JML-4	Spindle	1"x8TPI	1
5	JML-5	Key	5x25	1
6	BB-6005VV	Ball Bearing		1
7	BB-6004VV	Ball Bearing		1
8	JML-8	Wave Washer		1
9	TS-0267041	Set Screw	1/4-20x3/8	2
10	JML1014-110	Handlewheel		1
11	JML-11	Drift Rod		1
12	JML-12	Spindle Pulley Door		1
13	JML-13	Spring		1
14	JML-14	Roll Pin	3x10	2
15	TS-081C042	Round Head Screw	10#-24x5/8	2
16	TS-0560071	Hex Nut	10#	1
17	TS-0207071	Hex Socket Cap Screw	1/4-20x1-1/4	4
18	TS-0720071	Lock Washer	1/4	4
19	JML-19	Spindle Pulley		1
20	JML-20	Belt		1
21	JML-21E	Bed		1
22	JML-22	Motor Pulley Door		1
23	JML-23	Lock Knob	M8	1
24	JML-24	Pin		1
25	TS-1550061	Flat Washer	M8	1
26	JML-26	Spring		1
27	JML-27	Hex Cap Screw	M8x75	1
28	JML-28	Motor Pulley		1
29	TS-0050021	Hex Cap Screw	1/4-20x5/8	2
30	TS-0720071	Lock Washer	1/4	2
31	TS-0640081	Nylon Insert Lock Nut	5/16-18	1
32	TS-0051061	Hex Cap Screw	5/16-18x1-1/4	1
33	JML-33	Motor Bracket		1
34	JML-34	Handle Protector		1
35	JML-35E	Motor		1
	JML-35-1E	Capacitor(not show)		1
	JML-35-2E	Capacitor Cover(not show)		1
	JML-35-3	Motor Fan Cover(not show)		1
36	TS-0680031	Flat Washer	5/16	1
37	JML-37A	Lock Handle Assembly, Motor Plate		1
	JML-TRA	Tool Rest Assembly (41 thru 51 & 81)		1
41	JML-41	Tool Rest Body		1
42	JML-42	Tool Rest	6"	1
43	JML-43	Bolt		1
44	JML-44	Clamp		2
45	JML-45A	Lock Handle Assembly, Tool Rest Body		1

Index No.	Part No.	Description	Size	Qty.
49	JML-49	C-Ring		2
50	JML-50	Eccentric Rod		1
51	JML-51	Bushing		1
	708331	Live Center Assembly		1
52	JML-52	Live Center Head		1
52A	JML-52A	Center Point for Live Center		1
53	BB-6002ZZ	Ball Bearing		1
54	JML-54	Live Center Shaft		1
55	JML-55	Tailstock Spindle		1
56	JML-56	Leadscrew		1
57	JML-57	E-Ring		1
58	JML-58	Eccentric Rod		1
59	JML-59A	Lock Handle Assembly, Tailstock		1
60	JML-60	Tailstock		1
61	JML-61	Handlewheel		1
62	JML-62	Handle		1
63	JML-63	C-Ring		1
64	JML-64	Bolt		1
65	JML-65E	Magnetic Switch (VDE)		1
66	TS-081C022	Pan Head Screw	10#-24x3/8	2
67	JML-67E	Switch Bracket		1
68	JML-68	Round Head Machine Screw		2
69	JML-69	Switch Cover		1
70	JML-70E	Stain Relief Bushing		2
71	TS-0560071	Hex Nut	#10	2
72	JML-72	Cord Clamp		2
73	TS-081C062	Round Head Screw	#10-24x1	2
74	JML-74	Cord Protector		1
75	JML-75E	Power Cord(VDE)		1
79	JML-79	Safety Goggles		1
80	JML-80	Pad		4
81	JML-81	Clamp Nut		2
82	JML-81E	Ground Plate		1
83	TS-1540031	Hex Nut	M5	2
84	JML-84	Star Washer	M5	2
85	TS-1533062	Pan Head Screw	M5x20	2
86	TS-1523031	Set Screw	M6x10	3
87	JML1014-187	C-Ring	STW-9	1
88	JML1014-188	Spring		1
89	JML1014-189	Index Pin		1
90	TS-0267021	Set Screw	1/4-20x1/4	2
91	JML1014-191E	Speed Label		1
92	10000450	Adaptor		1

**JML-1014I
708375M**

	colour of strands	Litzenfarben	couleur des cordons
BK	black	schwarz	noir
WH	white	weiß	blanc
BU	blue	blau	bleu
YE	yellow	gelb	jaune
RD	red	rot	rouge
BN	brown	braun	brun
GY	grey	grau	gris
GNYE	green-yellow	grün-gelb	vert-jaune
OG	orange	orange	orange
VT	violet	violett	violet

	meaning of symbol	Bedeutung der Zeichen	interprétation
M	motor	Motor	moteur
S	switch	Schalter	interrupteur
C	condenser	Kondensator	condensateur
E	electronic unit	Elektronik Einheit	unité électronique
F	fuse	Sicherung	fusible
RS	reversing switch	Drehrichtungsschalter	commu. droite/gauche
CS	centrifugal switch	Fliehkraftschalter	déclencheur centrifuge
OL	overload cut-off	Überlastschuttschalter	déclencheur surcharge
LS	limit switch	Positionsendschalter	micro

230/50/1

