

JET

JJ-8-M

Surface Planer

10000260M ~230V 50Hz

PARTS LIST

JPW (TOOL) AG

Tämperlistrasse 5

CH-8117 Fällanden

Switzerland

Phone +41 44 806 47 48

Fax +41 44 806 47 58

www.jettools.com

P-10000260M

2018-03

Parts Breakdown for JJ-8-M Surface Planer--Part A (Fence – Assembly)

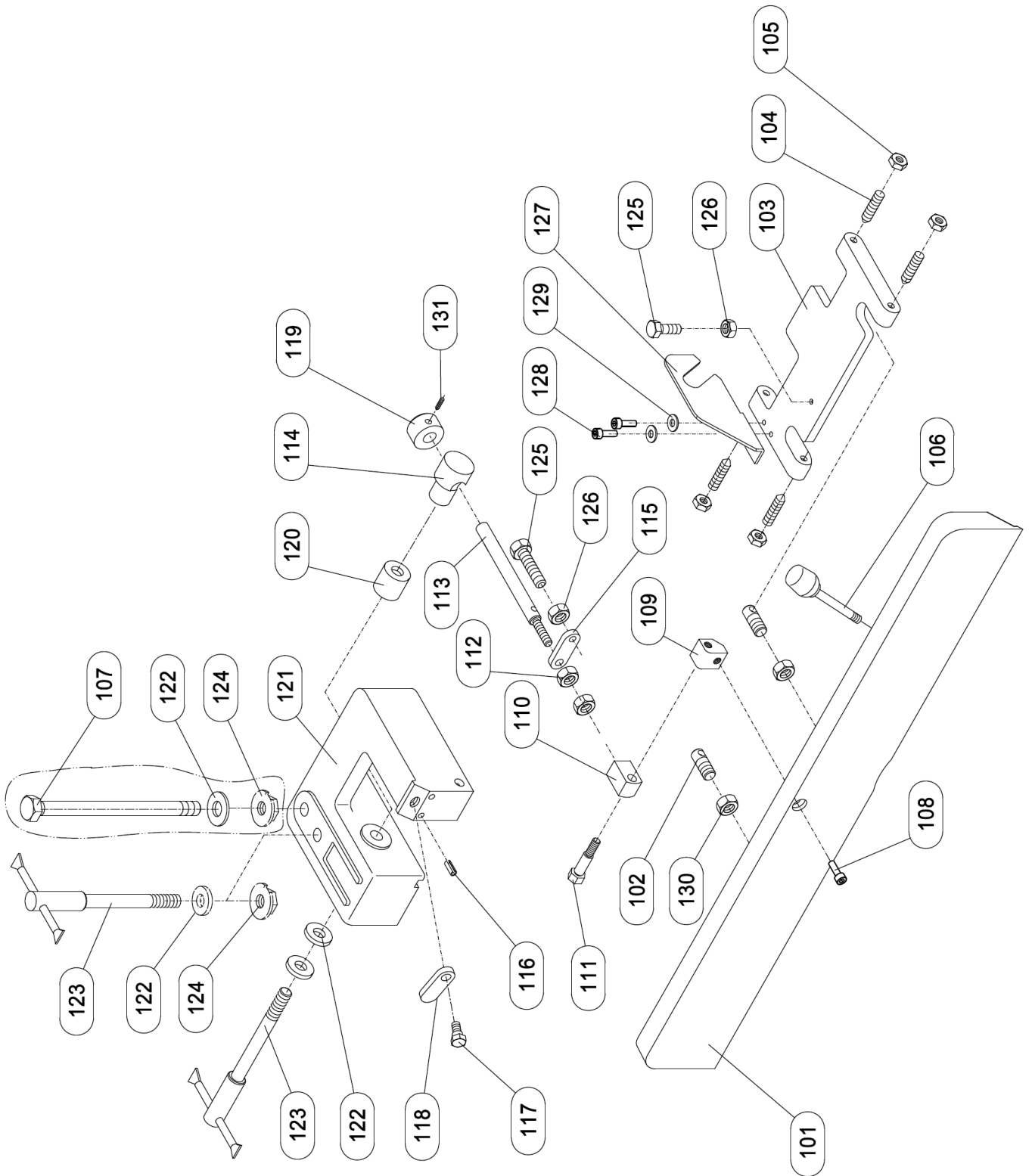

Parts List for JJ-8-M Surface Planer ----- Part A (Fence – Assembly)

Index No.	Part No.	Description	Size	Qty.
	JJ8-100	Fence Assembly Complete (#101 thru 132)		1
101	JJ8-101	Fence Body		1
102	JJ6-102	Fence Link		2
103	JJ8-103	Tilt Plate		1
104	JJ6-104	Threaded Stud	M10x40	4
105	JJ6-105	Hex Nut	M10	4
106	JJ6-106	Handle		1
107	JJ6-107	Long Bolt (for Packing)	M12x100	1
108	JJ6-108	Socket Head Cap Screw	M8x35	1
109	JJ6-109	Block A		1
110	JJ6-110	Block B		1
111	JJ6-111	Bolt		1
112	JJ6-112	Hex Nut	M12	2
113	JJ6-113	Hex Nut		1
114	JJ6-114	Swivel Block		1
115	JJ6-115	Plate A		1
116	JJ6-116	Spring Pin	4x12	2
117	JJ6-117	Hex Cap Bolt		1
118	JJ8-118	Plate B		1
119	JJ6-119	Sleeve		1
120	JJ6-120	Bushing		1
121	JJ8-121	Fence Bracket		1
122	JJ6-122	Flat Washer	12	3
123	JJ6-123	Lock Handle		2
124	JJ8-124	Lock Nut		1
125	JJ6-125	Hex Cap Screw	M8x35	2
126	JJ6-126	Hex Nut	M8	1
127	JJ6-127	Plate		1
128	JJ6-128	Socket Head Cap Screw	M8x16	2
129	JJ6-129	Flat Washer	8	2
130	JJ6-130	Hex Nut	M12x1	2
131	JJ6-131	Set Screw	M6x8	1

Parts Breakdown for JJ-8-M Surface Planer ----- Part B (Stand - Parts)

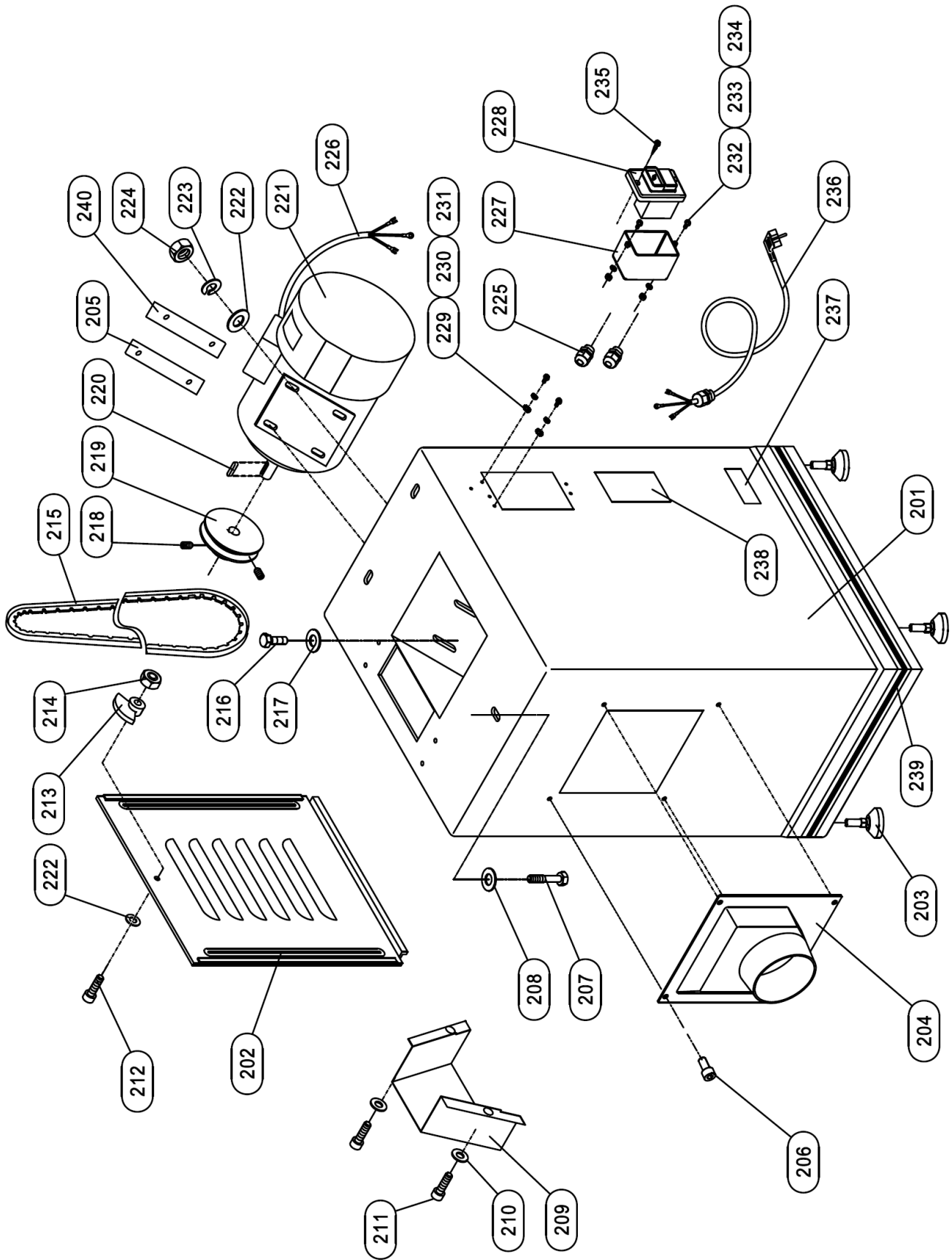

Parts List for JJ-8-M Surface Planer ----- Part B (Stand – Parts)

Index No.	Part No.	Description	Size	Qty.
201	JJ8-201	Stand Body		1
202	JJ6-202	Access Cover		1
203	JJ6-203	Bolt With Leveling Pad	M10	4
204	JJ6-204	Dust Chute		1
205	JJ8-205	Motor Base Plate A		1
206	JJ6-206	Socket Head Cap Screw	M5x10	4
207	JJ6-207	Hex Cap Bolt	M10x16	3
208	JJ6-208	Flat Washer	10	3
209	JJ8-209	Belt Guard	1	1
210	JJ6-210	Flat Washer	6	2
211	JJ6-211	Socket Head Cap Screw	M6x12	2
212	JJ6-212	Socket Head Cap Screw	M8x20	1
213	JJ6-213	Door Latch		1
214	JJ6-214	Lock Nut	M8	1
215	JJ6L-215	V-Belt (Raw Edge Cogged Belts)	A-870	1
216	JJ6-216	Hex Cap Bolt	M8x35	4
217	JJ6-217	Flat Washer	8	4
218	JJ6-218	Set Screw	M6x8	2
219	JJ6L-219A	Motor Pulley		1
220	JJ6L-220A	Key	8x7x35	1
221	JJ8-221EMA	Motor P2=1500W	230V 50Hz	1
	JJ8-221MF	Motor Fan (not shown)		1
	JJ8-221SCE	Starting Capacitor(not shown)	200uF/250V	1
	JJ8-221SCT	Running Capacitor(not shown)	35uF/450V	1
	JJ8-221JB	Junction Box (not shown)		1
	JJ8-221JBC	Junction Box Cover(not shown)		1
	JJ8-221MC	Motor Cover (not shown)		1
222	JJ6-222	Flat Washer	8	5
223	JJ6-223	Spring Washer	8	4
224	JJ6-224	Hex Nut	M8	4
225	JJ6-225	Strain Relief		3
226	JJ8-226A	Cord for Motor	0.7m-4Gx1.5mm ²	1
227	JJ6L-227A	Switch Box		1
228	JJ6L-228A	Switch 230V	DZ6-2 / 5P	1
229	JJ6-229	Star Washer	4	2
230	JJ6-230	Flat Washer	4	2
231	JJ6-231	Screw	M4x12	2
232	JJ6-232	Screw	M4x20	2
233	JJ6-233	Flat Washer	4	2
234	JJ6-234	Hex Nut	M4	2
235	JJ6-235	Screw	M4x12	2
236	JJ8-236	Power Cord	3Gx1.5mm ²	1
237	JET-92	JET LOGO	92x38	1
238	JJ6-238	JET Warning Label		1
239	JJ8-239	JET Stripe		1
240	JJ8-240	Motor Base Plate B		1

Parts Breakdown for JJ- 8-M Surface Planer ---Part C (Bed - Parts)

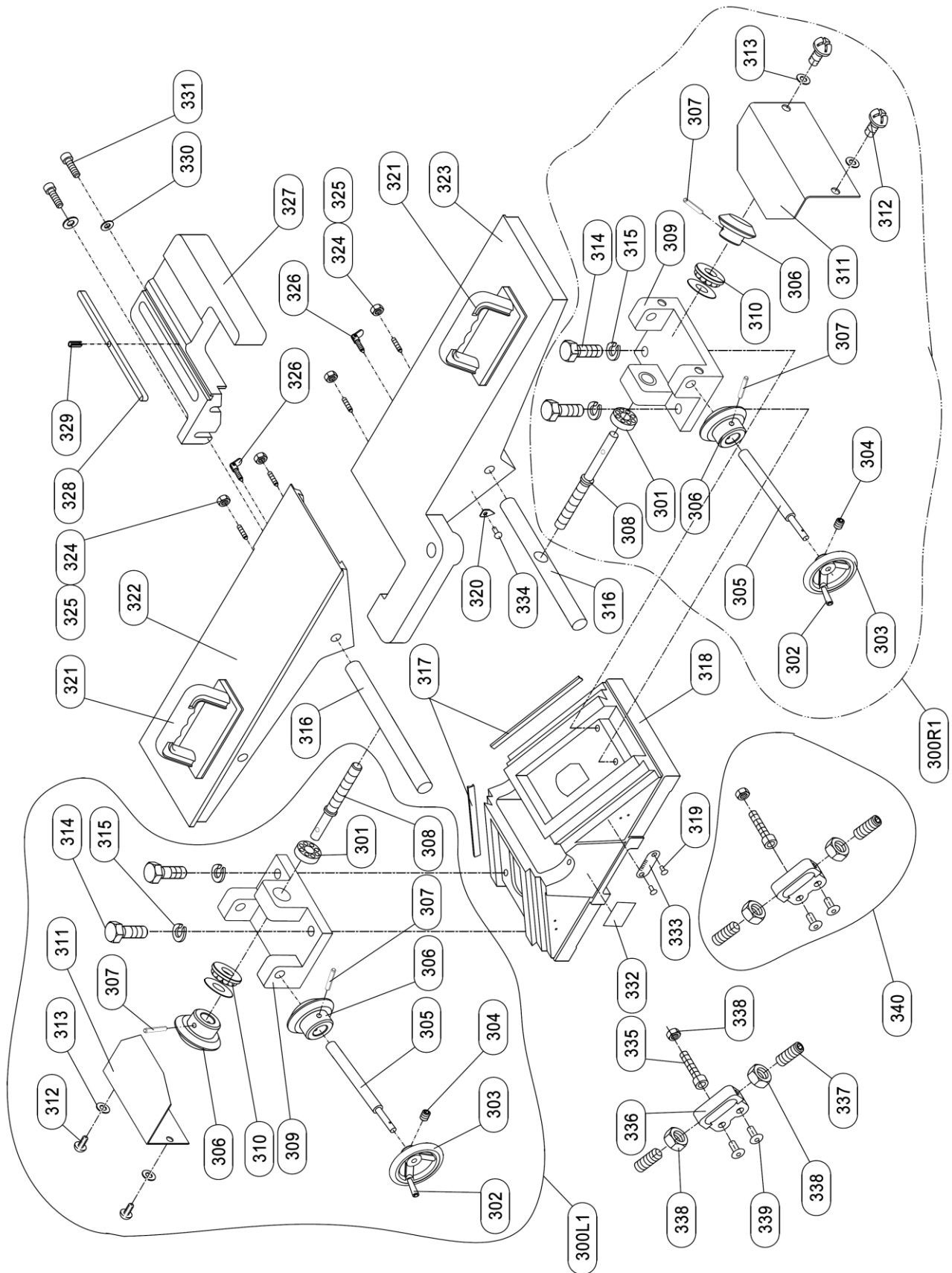

Parts List for JJ-8-M Surface Planer ----- Part C (Bed – Parts)

Index No.	Part No.	Description	Size	Qty.
300L1	JJ8-300L1	Adjusting Table Assembly (#301 thru 315)		1
300R1	JJ8-300R1	Adjusting Table Assembly (#301 thru 315)		1
301	JJ6-301	Bearing 6000	Ø10xØ26x8	1
302	JJ6-302	Handle		2
303	JJ6-303	Handwheel		2
304	JJ6-304	Set Screw	M6x8	2
305	JJ8-305	Adjusting Shaft		2
306	JJ6-306	Gear		4
307	JJ6-307	Pin	4x16	2
308	JJ6-308	Lead Screw		2
309	JJ6-309	Gear Base		2
310	JJ6-310	Bearing 51100	Ø10xØ24x9	2
311	JJ6-311	Gear Cover		2
312	JJ6-312	Screw	M5x10	4
313	JJ6-313	Flat Washer	5	4
314	JJ6-314	Hex Cap Bolt	M8x25	4
315	JJ6-315	Spring Washer	8	4
316	JJ8-316	Table Adjust Rod		2
317	JJ8-317	Gib		2
318	JJ8-318	Base		1
319	JJ6-319	Rivet		2
320	JJ6-320	Pointer		1
321	JJ6-321	Push Block		2
322	JJ8-322	Outfeed Table		1
323	JJ8-323	Infeed Table		1
324	JJ6-324	Hex Nut	M6	4
325	JJ6-325	Set Screw	M6x25	4
326	JJ6-326	Lock Screw		2
327	JJ8-327	Fence Base		1
328	JJ8-328	Spring Pin		1
329	JJ6-329	Key		2
330	JJ6-330	Flat Washer	10	2
331	JJ6-331	Socket Head Cap Screw	M10x35	2
332	JJ8-332	JET ID Label		1
333	JJ6-333	Depth Scale		1
334	JJ6-334	Pan Screw	M4x8	1
335	JJ6-335	Socket Head Cap Screw	M8x35	2
336	JJ6-336	Stop Base	M4x8	2
337	JJ6-337	Socket Head Cap Screw	M8x40	4
338	JJ6-338	Hex. Nut	M8	5
339	JJ6-339	Set Screw	M6x20	4
340	JJ6-340	Stop Assembly (#335 thru 339)		1

Parts Breakdown for JJ-8-M Surface Planer Part D (Cutterhead – Parts and Assembly)

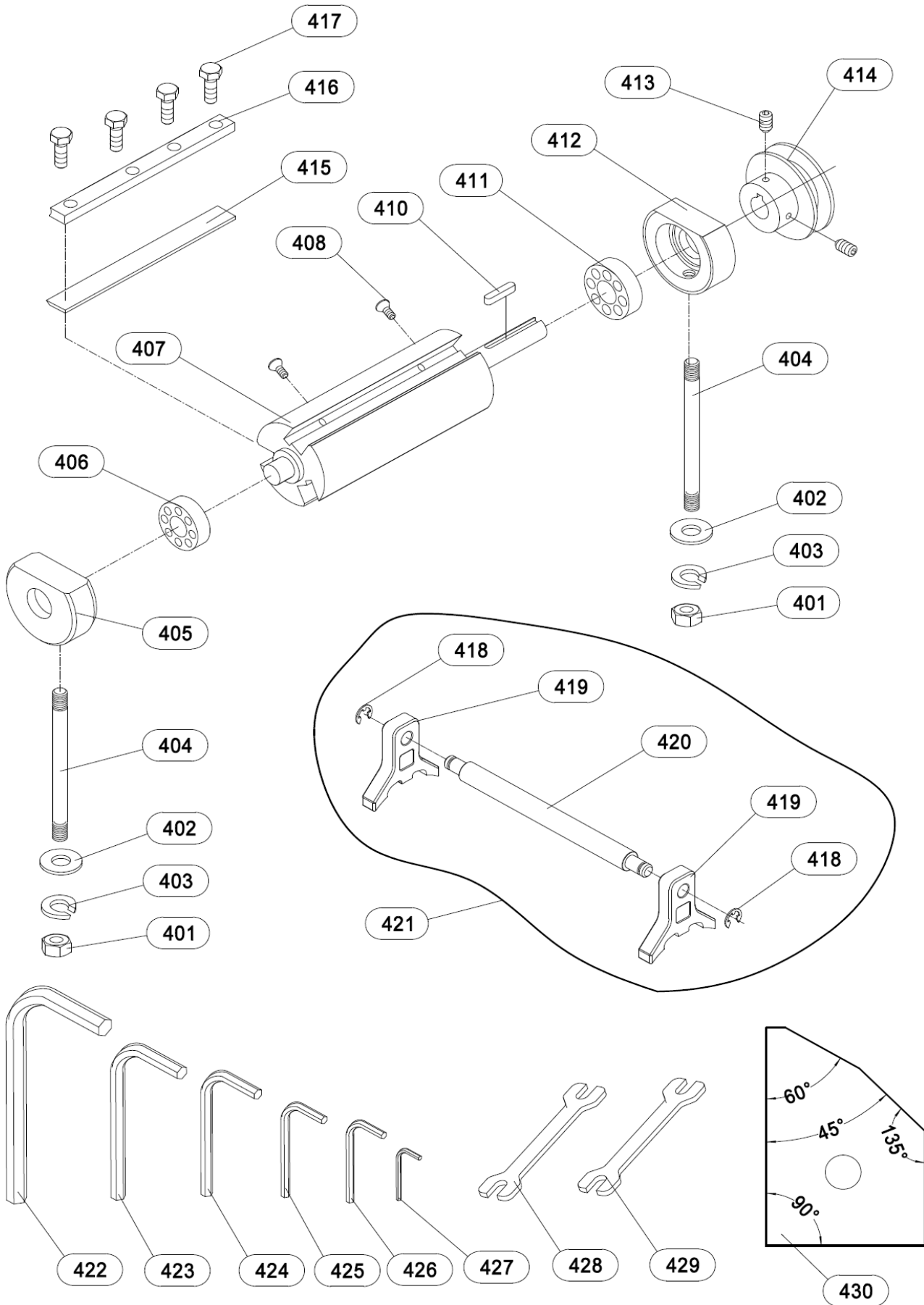

Parts List for JJ-8-M Surface Planer ----- Part D (Cutterhead – Parts and Assembly)

Index No.	Part No.	Description	Size	Qty.
	JJ8-400	Cutterhead Assembly(#401 thru 417)		1
401	JJ6-401	Hex Nut	M10	2
402	JJ6-402	Flat Washer	10	2
403	JJ6-403	Spring Washer	10	2
404	JJ8-404	Stud		2
405	JJ6-405	Left Bearing Housing		1
406	JJ6-406	Ball Bearing	6203-RZ	1
407	JJ8-407	Cutterhead		1
408	JJ6-408	Flat Head Socket Screw	M5x12	6
410	JJ6-410	Key	5x5x25	1
411	JJ6-411	Ball Bearing	6203-ZZ	1
412	JJ6-412	Right Bearing Housing		1
413	JJ6-413	Set Screw	M6x8	2
414	JJ6-414	Cutterhead Pulley		1
415	JJ8-415	Knife	205x19x3mm	3
416	JJ8-416	Knife Lock Bar		3
417	JJ6-417	Hex Screw		12
418	JJ6-418	C-Ring		2
419	JJ6-419	Knife Gauge		2
420	JJ8-420	Knife Gauge Bar		1
421	JJ8-421	Knife Gauge Assembly(#418 thru 420)		1
422	JJ6-422	Hex Wrench S8		1
423	JJ6-423	Hex Wrench S6		1
424	JJ6-424	Hex Wrench S5		1
425	JJ6-425	Hex Wrench S4		1
426	JJ6-426	Hex Wrench S3		1
427	JJ6-427	Hex Wrench S2.5		1
428	JJ6-428	Wrench S12-14		1
429	JJ6-429	Wrench S 8-10		1
430	JJ6-430	Angular Dimension		1

Parts Breakdown for JJ-8-M Surface Planer -----Part E (Guard)

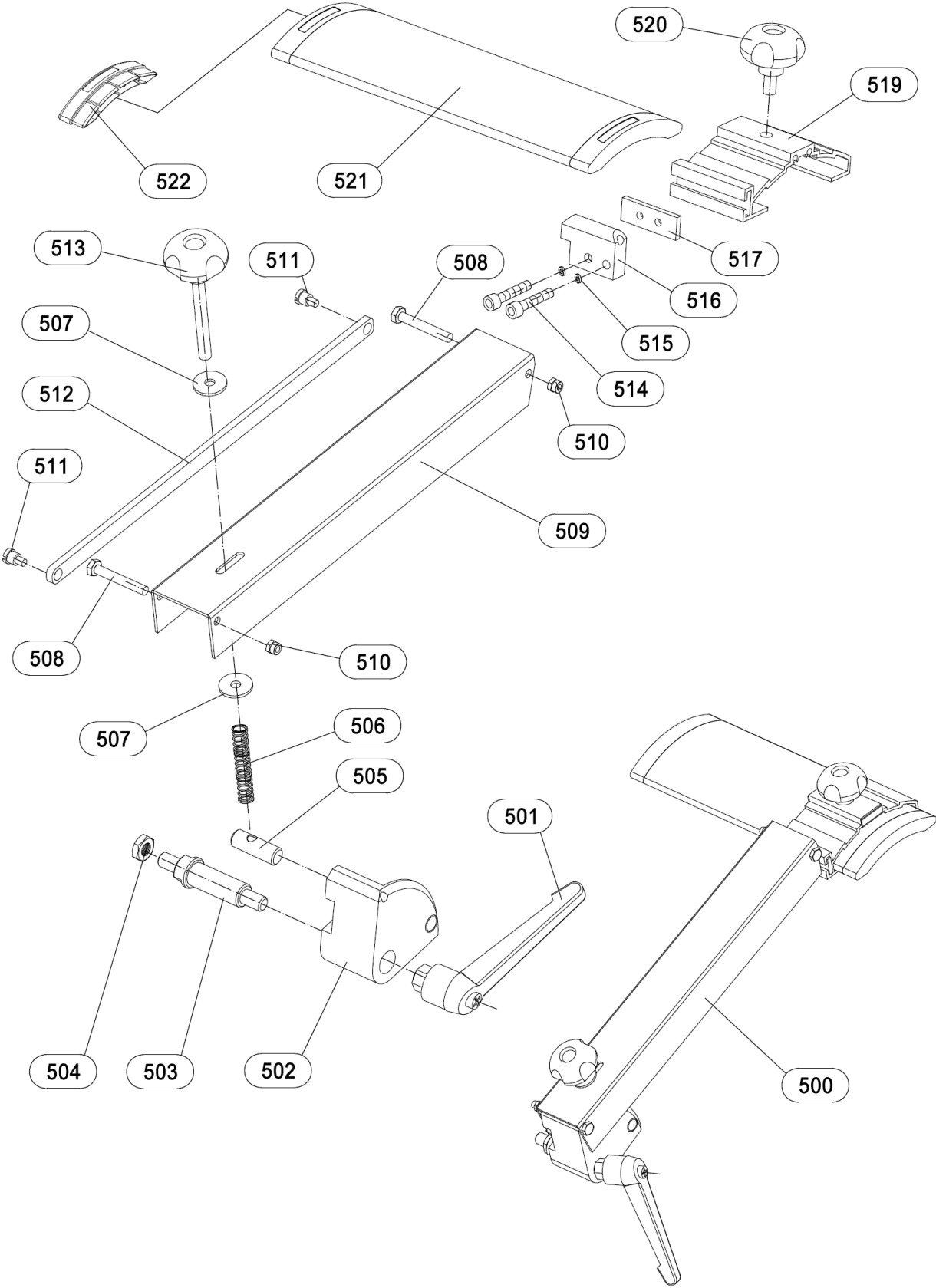

Parts List for JJ-8-M Surface Planer ----- Part E

Index No.	Part No.	Description	Size	Qty.
500	JJ6-500	Cutterhead Guard Assembly(#501 thru 521)		1
501	JJ6-501	Handle		1
502	JJ6-502	Locking Support		1
503	JJ6-503	Shaft		1
504	JJ6-504	Hex Nut	M10	1
505	JJ6-505	Revolving Shaft		1
506	JJ6-506	Spring		1
507	JJ6-507	Flat Washer	6	2
508	JJ6-508	Hex Head Bolt	M6x60	2
509	JJ6-509	Arm		1
510	JJ6-510	Lock Nut	M6	2
511	JJ6-511	Screw		2
512	JJ6-512	Long Shaft		1
513	JJ6-513	Handle		1
514	JJ6-514	Socket Head Cap Screw	M5x20	2
515	JJ6-515	Flat Washer	5	2
516	JJ6-516	Bracket		1
517	JJ6-517	Lock Plate		1
519	JJ8-519	Guard Plate Cover		1
520	JJ6-520	Knob		1
521	JJ8-521	Cutterblock Guard Profilew/Plastic End Covers		1
522	JJ6-522	Plastic End Covers		2

Wiring Diagram for JJ-8-M Surface Planer

10000260M..... ~ 230V, 50Hz

	colour of strands	Litzenfarben	couleur des cordons
BK	black	schwarz	noir
WH	white	weiß	blanc
BU	blue	blau	bleu
RD	red	rot	rouge
BN	brown	braun	brun
GY	grey	grau	gris
GNYE	green-yellow	grün-gelb	vert-jaune

	meaning of symbol	Bedeutung der Zeichen	interprétation
M	motor	Motor	moteur
S	switch	Schalter	interrupteur
C1	Condenser of running	Kondensator	condensateur
C2	Condenser of Starting	Kondensator	condensateur
n	centrifugal switch	Fliehkraftschalter	déclencheur centrifuge
OL	overload cut-off	Überlastschuttschalter	déclencheur surcharge
LS	limit switch	Positionsendschalter	micro
SB	E-stop	Not-Aus Taster	arret d'urgence

