

# **JET**

## **JMD-1L Milling Drilling Center**

50000045M ... JMD-1L ...1~230V 50Hz

### **PARTS LIST**

**JPW (Tool) AG**

Tämperlistrasse 5  
CH-8117 Fällanden  
Switzerland

Phone +41 44 806 47 48

Fax +41 44 806 47 58

[www.jettools.com](http://www.jettools.com)



# Parts Breakdown For JMD-1L Milling Drilling Center (1)

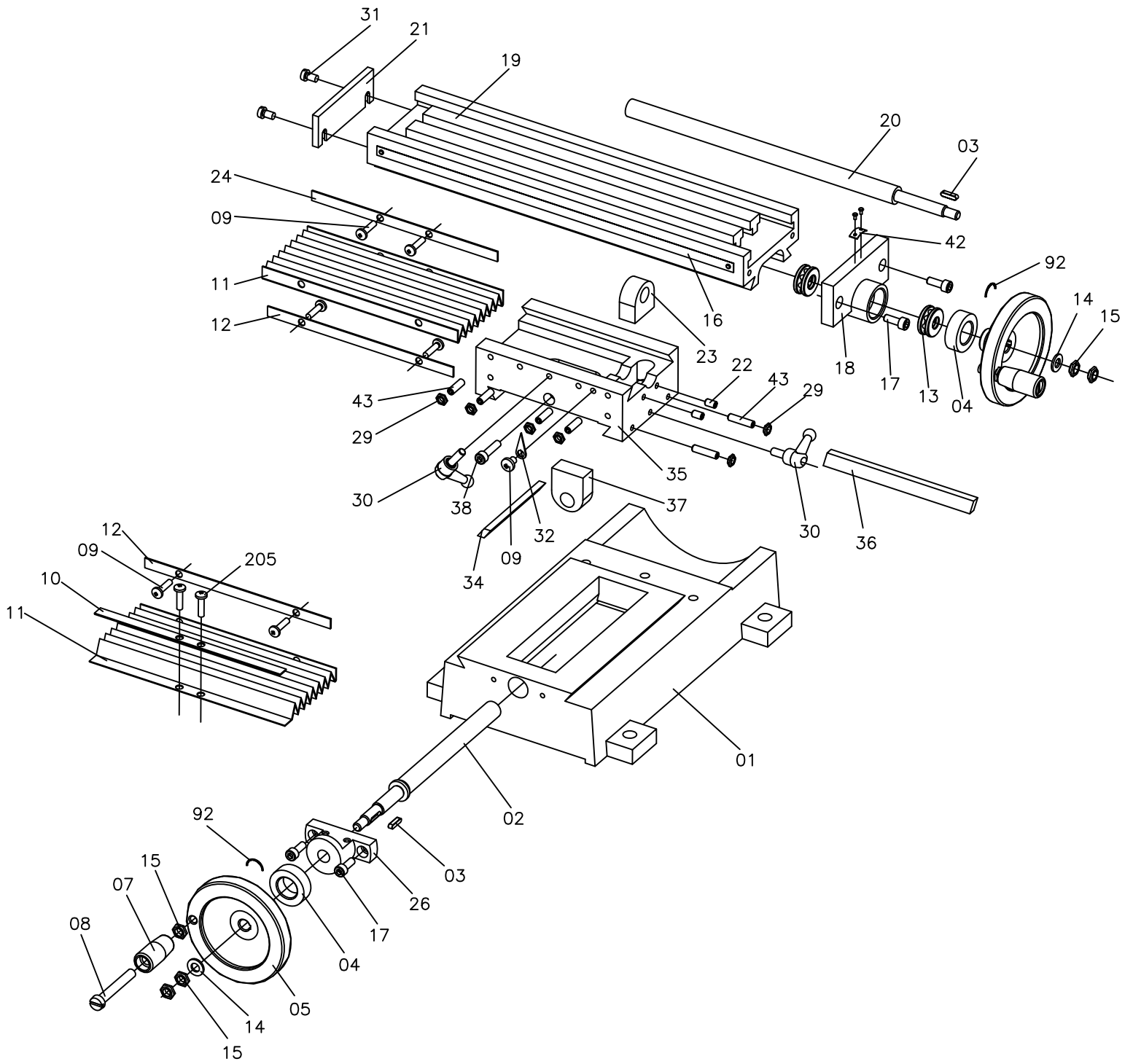

# Parts Breakdown For JMD-1L Milling Drilling Center (2)

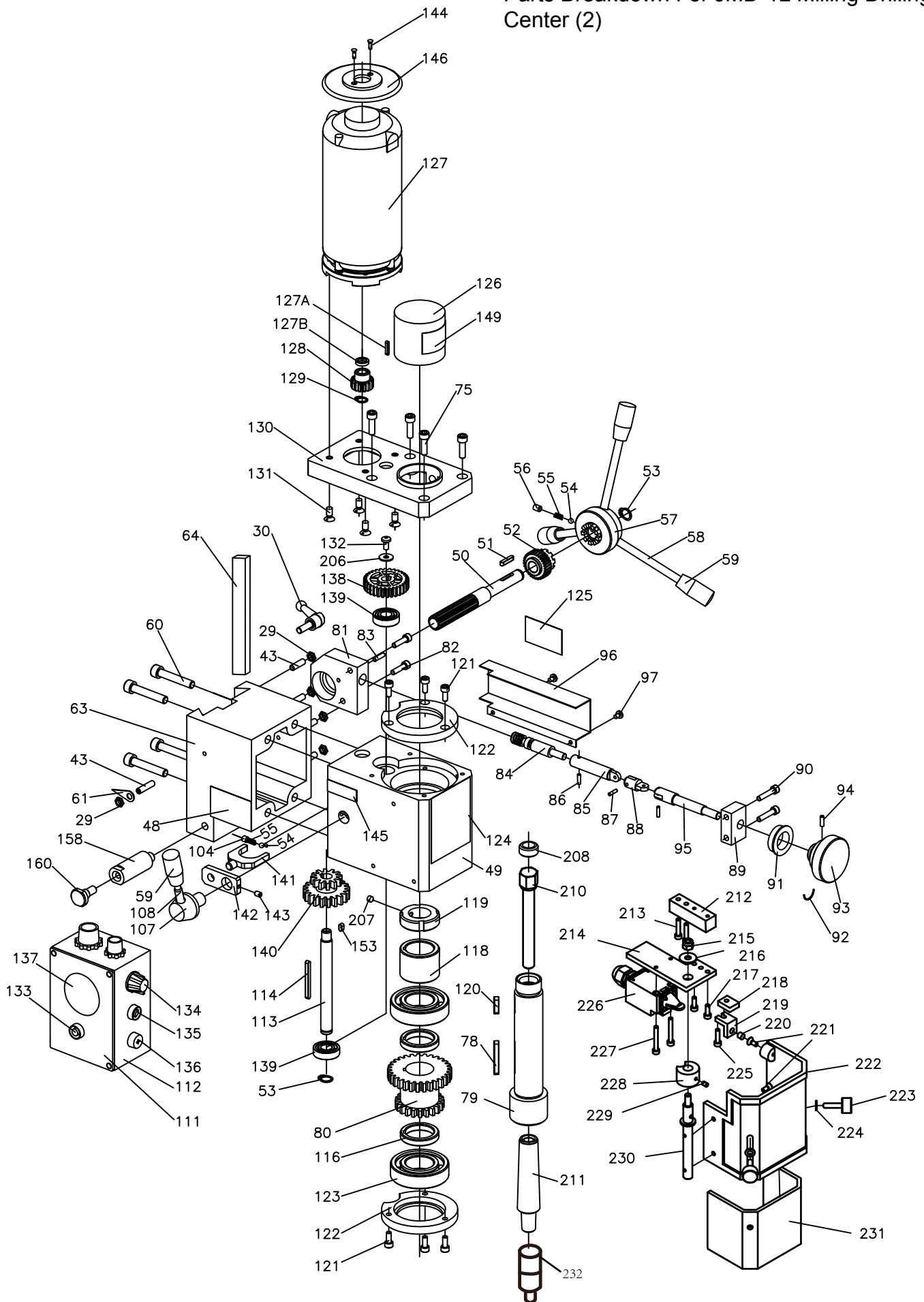

# Parts Breakdown For JMD-1L Milling Drilling Center (3)

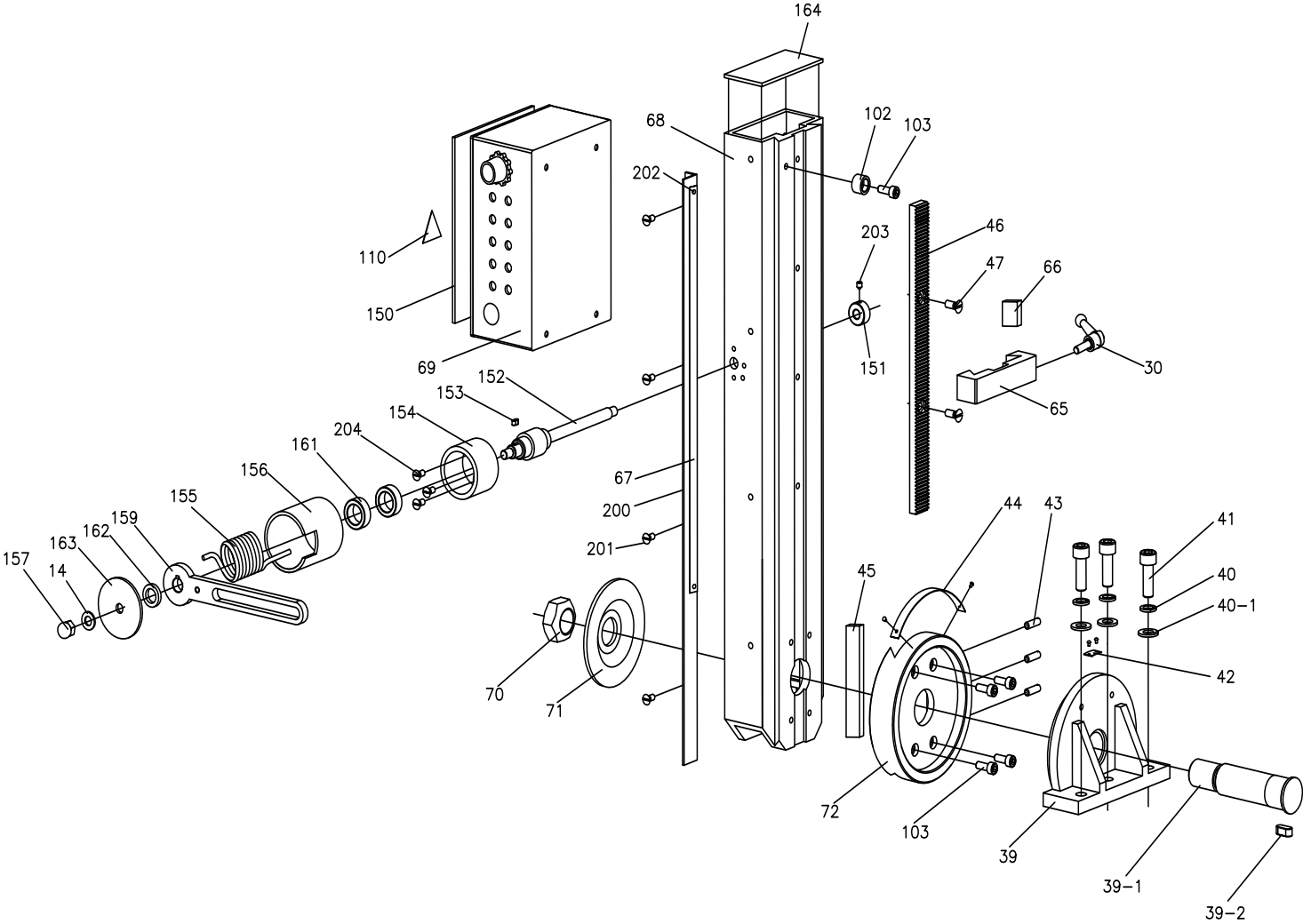

**Part List for JMD-1L Milling Drilling Center**

<b>No.</b>	<b>Part no.</b>	<b>Description</b>	<b>Size</b>	<b>Qty.</b>
1	JMD1L-001	Base		1
2	JMD1L-002	Cross leadscrew		1
3	JMD1L-003	Key	4x16	2
4	JMD1L-004	Dial		2
5	JMD1L-005	Hand wheel		2
6	JMD1L-007	Handle sleeve		2
7	JMD1L-008	Screw	M8 x 55	2
8	JMD1L-009	Cap screw	M6 x 8	7
9	JMD1L-010	Holding plate (1)		1
10	JMD1L-011	Dust guard cover		2
11	JMD1L-012	Holding plate(2)		2
12	JMD1L-013	Ball bearing	8200	2
13	JMD1L-014	Washer		3
14	JMD1L-015	Nut	M8	6
15	JMD1L-016	Y-axis ruler		1
16	JMD1L-017	Cap screw	M6x16	4
17	JMD1L-018	Y-axis bearing seat		1
18	JMD1L-019	Working table		1
19	JMD1L-020	Y-axis feeding screw		1
20	JMD1L-021	End cover		1
21	JMD1L-022	Screw	M6x10	2
22	JMD1L-023	Y-axis screw nut		1
23	JMD1L-024	Holding plate(3)		1
24	JMD1L-026	Screw seat		1
25	JMD1L-029	Nut	M6	11
26	JMD1L-030	Handle		4
27	JMD1L-031	Screw	M6 x 10	2
28	JMD1L-032	Guide finger		1
29	JMD1L-034	X-axis wedge		1
30	JMD1L-035	Saddle		1
31	JMD1L-036	Y-axis wedge		1
32	JMD1L-037	X-axis screw nut		1
33	JMD1L-038	Cap screw	M6 x 25	1
34	JMD1L-039	Fuselage seat		1
35	JMD1L-039-1	Shaft		1
36	JMD1L-039-2	Key	8X12	1
37	JMD1L-040	Spring insert		3
38	JMD1L-040-1	Washer		3
39	JMD1L-041	Cap screw	M10 x 30	3
40	JMD1L-042	Guide finger		2
41	JMD1L-043	Set screw	M6 x 22	14
42	JMD1L-044	Ruler		1
43	JMD1L-045	Wedge		1
44	JMD1L-046	Gear rack		1
45	JMD1L-047	Cap screw	M6 x 12	2
46	JMD1L-048	Name plate		1

**Part List for JMD-1L Milling Drilling Center**

<b>No.</b>	<b>Part no.</b>	<b>Description</b>	<b>Size</b>	<b>Qty.</b>
47	JMD1L-049	Spindle box		1
48	JMD1L-050	Gear		1
49	JMD1L-051	Key	4 x 25	1
50	JMD1L-052	Bevel gear	29T	1
51	JMD1L-053	R etaining ring	12	2
52	JMD1L-054	Ball	Φ5.0	2
53	JMD1L-055	Spring	0.8 x 0.8 x 10	2
54	JMD1L-056	Screw	M6 x 8	1
55	JMD1L-057	Handle stock		1
56	JMD1L-058	Operating lever		3
57	JMD1L-059	Long handle sleeve		4
58	JMD1L-060	Cap screw	M8 x 25	4
59	JMD1L-061	Guide finger		1
60	JMD1L-063	Spindle box seat		1
61	JMD1L-064	Wedge		1
62	JMD1L-065	Limit block		1
63	JMD1L-066	Wedge		1
64	JMD1L-067	Ruler		1
65	JMD1L-068	Column		1
66	JMD1L-069	Electric box		1
67	JMD1L-070	Lock nut	M24	1
68	JMD1L-071	Washer		1
69	JMD1L-072	Connecting strut		1
70	JMD1L-075	Screw	M6X20	4
71	JMD1L-078	Key	5 x 5 x 40	1
72	JMD1L-079	Spindle		1
73	JMD1L-080	Duplicate gear	21/29T	1
74	JMD1L-081	Support block		1
75	JMD1L-082	Screw	M5 x 20	2
76	JMD1L-083	Pin	4 x 15	1
77	JMD1L-084	Worm		1
78	JMD1L-085	Sleeve		1
79	JMD1L-086	Pin	3 x 12	2
80	JMD1L-087	Pin	3 x 12	1
81	JMD1L-088	Adjustable union		1
82	JMD1L-089	Bracket		1
83	JMD1L-090	Screw	M5 x 25	2
84	JMD1L-091	Dial		1
85	JMD1L-092	Damp spring		3
86	JMD1L-093	Small hand wheel		1
87	JMD1L-094	Screw	M5 x 16	1
88	JMD1L-095	Small shaft		1
89	JMD1L-096	Cover		1
90	JMD1L-097	Screw	M4 x 6	2
91	JMD1L-102	Upper end washer		1
92	JMD1L-103	Upper end screw	M6 x 16	5

### Part List for JMD-1L Milling Drilling Center

No.	Part no.	Description	Size	Qty.
93	JMD1L-104	Set screw	M6 x 6	1
94	JMD1L-107	Handle seat		1
95	JMD1L-108	Double head bolt	M8 x 70	1
96	JMD1L-110	Warning label		1
97	JMD1L-111	Electric box cover		1
98	JMD1L-112	Electric box		1
99	JMD1L-113	Shaft (1)		1
100	JMD1L-114	Key	4 x 4 x 45	1
101	JMD1L-116	Spacing ring		2
102	JMD1L-118	Spacing ring		1
103	JMD1L-119	Spindle nut		1
104	JMD1L-120	Key	5 x 5 x 30	1
105	JMD1L-121	Cap srew	M5 x 8	6
106	JMD1L-122	Bearing cover		2
107	JMD1L-123	Ball bearing	80206	2
108	JMD1L-124	Name plate		1
109	JMD1L-125	Fine feeding laebel		1
110	JMD1L-126	Protecting cover		1
111	JMD1L-127	Motor	350W	1
112	JMD1L-127A	Key	3X16	1
113	JMD1L-127B	Motor gear washer		1
114	JMD1L-128	Motor gear	21/29T	1
115	JMD1L-129	Intering ring	9	1
116	JMD1L-130	Motor seat		1
117	JMD1L-131	Flat screw	M6 x 12	4
118	JMD1L-132	Round screw	M5 x 8	1
119	JMD1L-133	Yellow lamp		1
120	JMD1L-134	Speed control knob		1
121	JMD1L-135	Green lamp		1
122	JMD1L-136	Fuse box		1
123	JMD1L-137	Emergency stop switch		1
124	JMD1L-138	Gear	30T	1
125	JMD1L-139	Ball bearing	80101	2
126	JMD1L-140	Transmission gear	20/12T	1
127	JMD1L-141	Fork		1
128	JMD1L-142	Linking board		1
129	JMD1L-143	Set screw	M5 x 8	1
130	JMD1L-144	Self-tapping Screw	ST2.9 x 8	2
131	JMD1L-145	H/L label		1
132	JMD1L-146	Motor cover		1
133	JMD1L-149	Warming lable		1
134	JMD1L-150	PC board		1
135	JMD1L-151	Lock sleeve		1
136	JMD1L-152	Rotor shaft		1
137	JMD1L-153	Key	4 x 6	2
138	JMD1L-154	Spring support		1

**Part List for JMD-1L Milling Drilling Center**

<b>No.</b>	<b>Part no.</b>	<b>Description</b>	<b>Size</b>	<b>Qty.</b>
139	JMD1L-155	Torsion spring		1
140	JMD1L-156	Cover		1
141	JMD1L-157	Nut	M8	1
142	JMD1L-158	Prop		1
143	JMD1L-159	Supporting shank		1
144	JMD1L-160	Screw		1
145	JMD1L-161	Washer		2
146	JMD1L-162	Washer		1
147	JMD1L-163	Cover		1
148	JMD1L-164	Top cover		1
149	JMD1L-200	Dial seat		1
150	JMD1L-201	Screw	M3X8	4
151	JMD1L-202	Rivet		10
152	JMD1L-203	Screw	M5X6	1
153	JMD1L-204	Screw	M5X8	3
154	JMD1L-205	Screw	M5X8	2
155	JMD1L-206	Washer		1
156	JMD1L-207	Screw	M6X8	1
157	JMD1L-208	Fixed sleeve		1
158	JMD1L-210	Shaft	M12	1
159	JMD1L-211	Handle	B16	1
160	JMD1L-212	Connect plate		1
161	JMD1L-213	Screw	M4X20	2
162	JMD1L-214	Support plate		1
163	JMD1L-215	Nut	M6	1
164	JMD1L-216	Washer		1
165	JMD1L-217	Washer		2
166	JMD1L-218	Connect plate		1
167	JMD1L-219	Stop dog		1
168	JMD1L-220	Magnet		1
169	JMD1L-221	Screw	M4X10	3
170	JMD1L-222	Protecting cover		1
171	JMD1L-223	Washer		2
172	JMD1L-224	Safety & limit switch		2
173	JMD1L-225	Screw	M4X16	1
174	JMD1L-226	Spacer bush		1
175	JMD1L-227	Screw	M4X30	2
176	JMD1L-228	Shaft		1
177	JMD1L-229	Screw	M4X6	1
178	JMD1L-230	Shaft		1
179	JMD1L-231	Protecting cover		1
180	JMD1L-232	Keyless drill chuck	B16	1



**50000045M .....JMD-1L .....1~230V,50Hz**

