



JWBS-15

Woodworking Bandsaw

Holz-Bandsäge

Scie à ruban

Ленточнопильный станок

JWBS-15-M.....714600M....1~230V, 50Hz

JWBS-15-T.....714650T 3~400V, 50Hz

PARTS LIST

JPW (Tool) AG
Ackerstrasse 45,
CH-8610 Uster
Switzerland



www.jettools.com

P-714600M / 714650T

2019-07

JWBS-15 CE Band saw Assembly – Exploded View

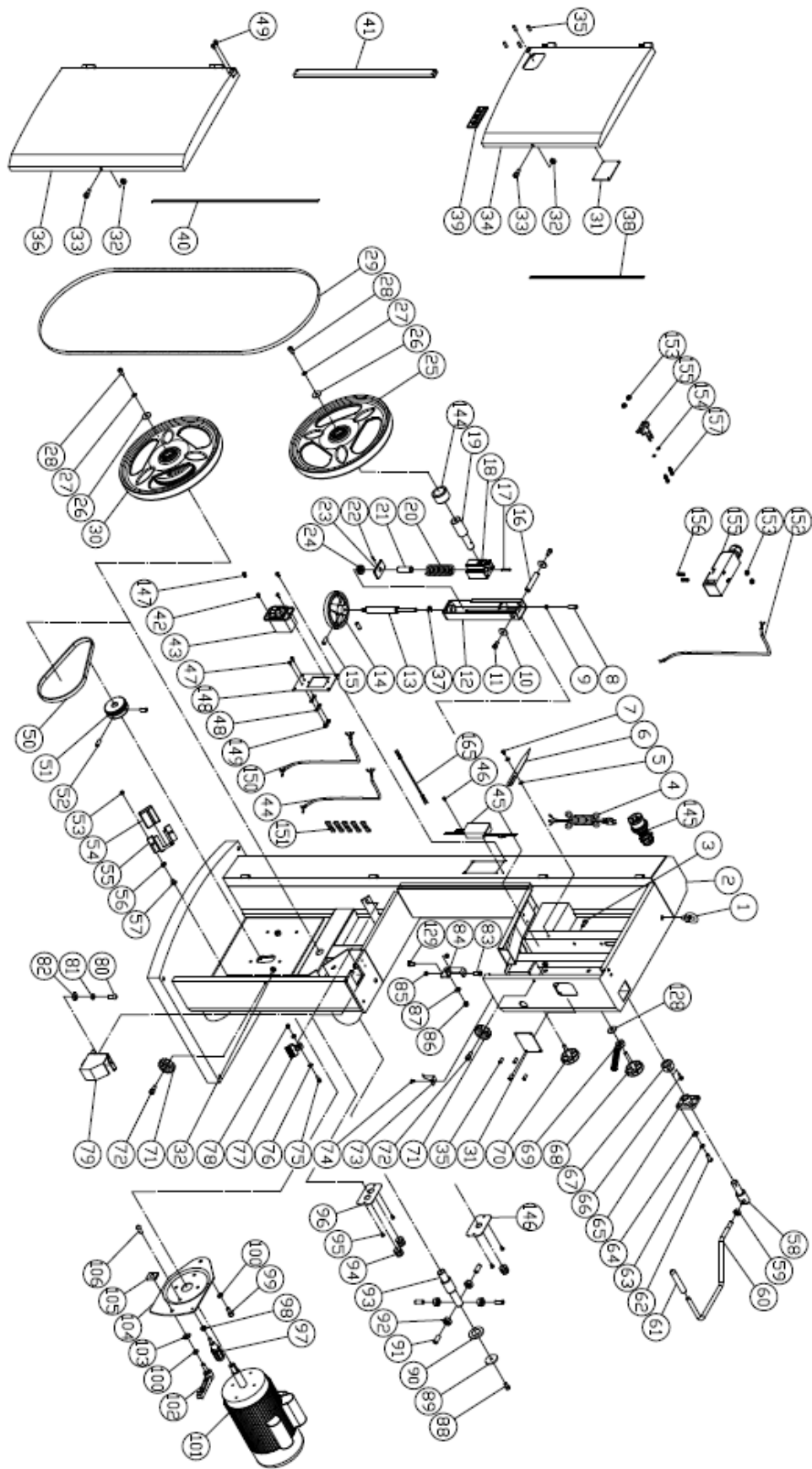

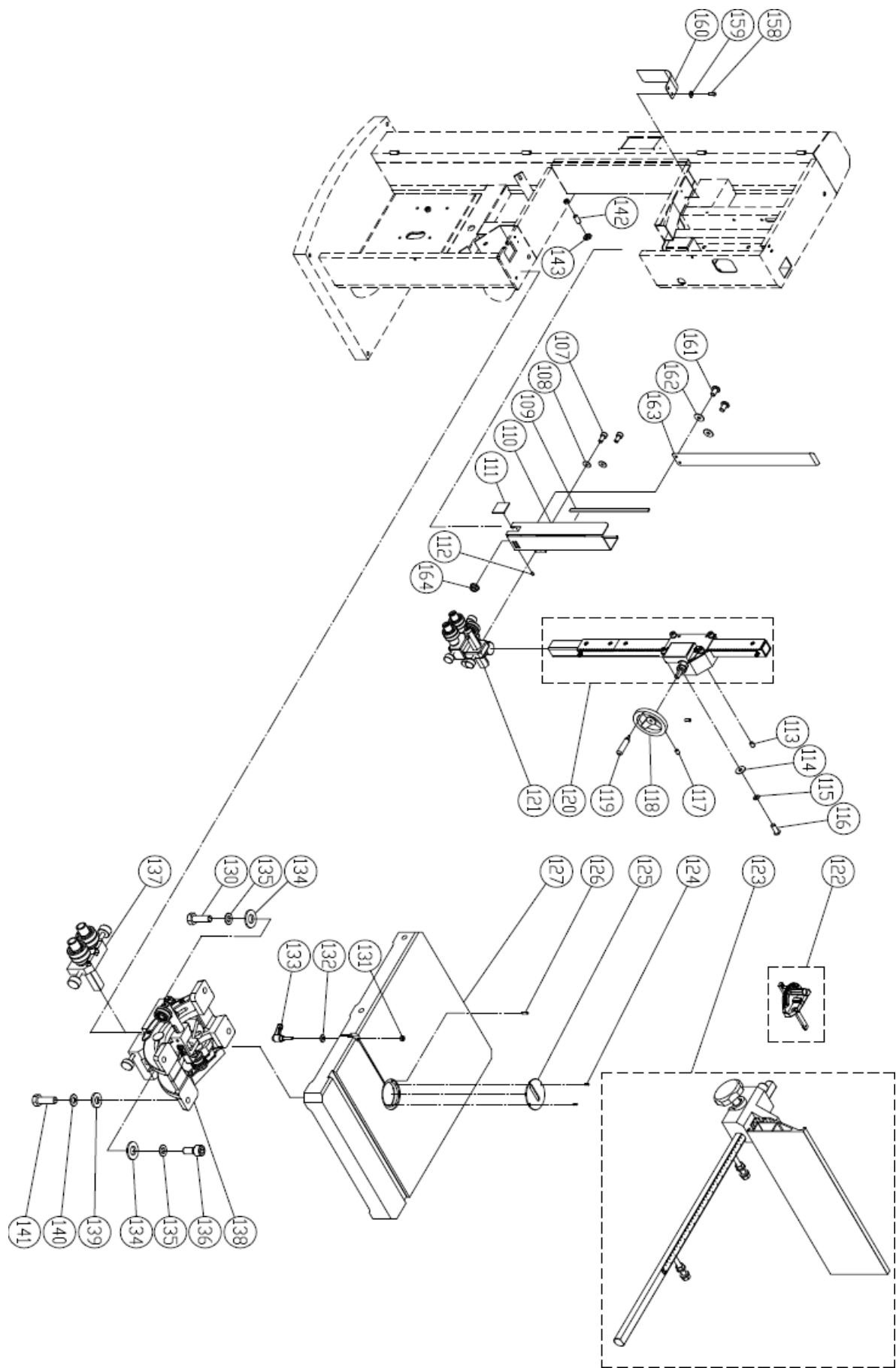

JWBS-15 CE Band saw Assembly – Parts List

Index No.	Part No.	Description	Size	Qty
1	PM1500-004	Lifting Ring	M10	1
2	JWBS15M-102	Machine Main Body Frame		1
3	TS-1482021	Hex Cap Bolt	M6x12	1
4	JWBS15M-104	CE Power Cord (1PH)	1.5mm ² x3Cx3.3M	1
	JWBS15M-104-AU	CE Power Cord (1PH) with SAA 10A Plug	1.0mm ² x3Cx3.3M	1
	JWBS15T-104	CE Power Cord (3PH)	1.0mm ² x4Cx3.3M	1
5	TS-1550041	Flat Washer	M6	2
6	PM1500-011	Tension Pointer		1
7	PM1500-012	Step Screw		1
8	TS-1503111	Socket Head Cap Screw	M6x50	1
9	TS-2311061	Hex Nut	M6	1
10	TS-1550061	Flat Washer	M8	2
11	TS-1504031	Socket Head Cap Screw	M8x16	2
12	JWBS15-112	Upper Wheel Sliding Bracket		1
13	JWBS15-113	Adjusting Bolt		1
14	JWBS15-114	Handwheel	6"	1
15	TS-1523041	Set Screw	M6x12	2
16	JWBS15-116	Upper Shaft		1
17	JWBS15-117	Spring Pin	Ø5x36	1
18	JWBS15-118	Upper Wheel Sliding Bracket		1
19	JWBS15-119	Upper Wheel Shaft		1
20	JWBS15-120	Spring		1
21	PM1500-010-02	Bushing		1
22	JWBS15-122	Pin	Ø3x20	1
23	JWBS15-123	Locate Block		1
24	BB-51201	Bearing	51201	1
25	PM1500-019	Upper Wheel Assembly	Ø15"	1
26	TS-1550061	Flat Washer	M8	2
27	TS-2361081	Spring Washer	M8	2
28	TS-1504041	Socket Head Cap Bolt	M8x20	2
29	JWBS15-129	Saw Blade	133"L x 1/2" W x 0.026"T x 6 TPI	1
30	PM1500-020	Lower Wheel Assembly	Ø15"	1
31	PM1500-050	Viewing Window		2
32	TS-1541021	Nylon Nut	M6	4
33	TS-1503021	Socket Head Cap Screw	M6x10	2
34	JWBS15M-134	Upper Cabinet Door		1
35	JWBS15-135	Socket Head Cap Screw	M4x8	8
36	JWBS15M-136	Lower Cabinet Door		1
37	PM1800B-027-026	Retaining Ring	E15	1
38	JWBS15-138	Sponge	515x10mm T=1	1
39	JET-138-R2000	Jet Logo	138x57mmx R2000	1
40	JWBS15-140	Sponge	760x10mm T=1	1
41	JWBS15M-141	Cabinet Door Connection Tube		1
42	SF-050200	Pan Head Bolt w/Flange	M5x10	2
43	JWBS-15M-143	CE on/off Switch (KJD-11)	230V, 1PH	1
	JWBS-15T-143	CE on/off Switch (KJD-11)	400V, 3PH	1
44	JWBS15M-144	CE Motor Cord	1.5mm ² x3Cx1.6M	1
	JWBS15T-144	CE Motor Cord	1.0mm ² x4Cx1.6M	1
45	136374	Regulator IC Board	DC-90V	1
46	ST039200	Tapping Screw	M3.5x8	1
47	TS-1533032	Pan Head Screw	M5x10	2
48	TS-0733041	Ext. Tooth Lock Washer	M5	4
49	TS-2245102	Socket Head Button Screw	M5x10	4
50	JWBS15-150	Poly V Belt	350J9	1
51	PM1500-025	Motor Pulley		1
52	TS-1523041	Set Screw	M6x12	2
53	TS-2311061	Hex Nut	M6	2

Index No.	Part No.	Description	Size	Qty
54	JWBS18DX-249	Dust Collect Insert		1
55	JWBS15-155	Fixed Plate		1
56	TS-2361061	Spring Washer	M6	2
57	TS-2246122	Socket Head Button Screw	M6x12	2
58	PM1500-074	Tension Quick Release Lever Shaft		1
59	TS-1540083	Hex Nut	M12	1
60	JWBS15-160	Tension Quick Release Lever		1
61	JWBS15-161	Grip		1
62	TS-2248202	Socket Head Button Screw	M8x20	4
63	TS-2361081	Spring Washer	M8	4
64	TS-1550061	Flat Washer	M8	4
65	PM1500-070	Shaft Fixed Block		1
66	TS-1503061	Socket Head Cap Screw	M6x25	1
67	PM1500-069	Cam		1
68	JWBS15-168	Lock Knob	M10x53	1
69	PM1500-068	Lock Handle	M10	1
70	JWBS15-170	Lock Knob	M10x25	1
71	135041	Knob		2
72	TS-1503051	Socket Head Cap Screw	M6x20	2
73	JWBS15-173	Pointer		1
74	6286494	Pan Head Screw	M5x6	1
75	TS-1482051	Hex Cap Screw	M6x25	1
76	TS-1550041	Flat Washer	M6	2
77	PM1500-058	Brush		1
78	TS-1541021	Hex Nylon Lock Nut	M6	1
79	JWBS15-179	Lower Blade Guard		1
80	TS-2246082	Socket Head Button Screw	M6x8	2
81	TS-2361061	Lock Washer	M6	2
82	TS-1550041	Flat Washer	M6	2
83	TS-1490041	Hex Cap Screw	M8x25	1
84	JWBS15-184	Support Plate		1
85	TS-1541031	Hex Nut	M8	1
86	TS-1541031	Nylon Nut	M8	1
87	TS-1550061	Flat Washer	M8	2
88	TS-1504041	Socket Head Cap Screw	M8x20	1
89	PM1500-077	Washer		1
90	PM1500-137	Plate		1
91	TS-1524051	Set Screw	M8x20	4
92	TS-1540061	Hex Nut	M8	4
93	JWBS15-193	Lower Wheel Shaft		1
94	PM1500-062	Strain Relief	PG13.5	2
95	PM1500-039	Tapping Screw	M4x8	2
96	PM1500-083	Strain Relief Fixed Plate		1
97	JWBS15-197	Handle		1
98	TS-1540061	Hex Nut	M8	1
99	TS-149105	Hex Cap Screw	M10x35	1
100	TS-2361101	Spring Washer	M10	2
101	JWBS15-1101E	Motor	1.1kW / 230V/ 1PH	1
	JWBS15-1101ERC	Running Capacitor (not shown)	35µF, 350VAC	1
	JWBS20B-188EBR	Motor Brake Assembly (not shown)		1
	JWBS15-1101EFC	Motor Fan Cover (not shown)		1
	JWBS15-1101AE	Motor	1.5kW / 400V/ 3PH	1
	JWBS20B-188EBR	Motor Brake Assembly (not shown)		1
	JWBS15-1101AEFC	Motor Fan Cover (not shown)		1
	JWBS18B-1101ACS	Centrifugal Switch (not shown)		1
102	PM1500-015	Motor Bracket Lock Handle	M10x33	1
103	TS-1550071	Flat Washer	M10	1
104	JWBS15-1104	Motor Bracket		1
105	PM1500-038	Locating Block		1

Index No.	Part No.	Description	Size	Qty
106	TS-2248202	Socket Head Button Screw	M8x20	4
107	TS-1502031	Socket Head Cap Screw	M5x12	2
108	TS-1550031	Flat Washer	M5	2
109	JWBS15-1109	Magnet	7x340mm	1
110	JWBS15M-1110	Blade Guard Cover		1
111	PM1800B-093	Viewing Window		1
112	TS-1521011	Set Screw	M4x4	2
113	5302731	Set Screw	M8x6	4
114	TS-1550061	Flat Washer	M8	4
115	TS-2361081	Spring Washer	M8	4
116	TS-2248202	Socket Head Button Screw	M8x20	4
117	TS-1523041	Set Screw	M6x12	2
118	JWBS15-1118	Handwheel	5"	1
119	JWBS15-1119	Handle	M8	1
120	JWBS15-1120	Guide Bar Bracket Assembly		1
121	JWBS15-1121	Upper Blade Guide Assembly		1
122	JWBS15-1122	Miter Gauge Assembly		1
123	JWBS15-1123	Rip Fence Assembly		1
124	JWBS15-1124	Roll Pin	Ø4x8	2
125	JWBS15-1125	Table Insert		1
126	TS-1522011	Set Screw	M5x5	3
127	JWBS15-1127	Table	21-1/2"x16"	1
130	TS-149105	Hex Cap Screw	M10x35	1
131	TS-1540061	Hex Nut	M8	1
132	TS-1550061	Flat Washer	M8	1
133	JWBS15-1133	Handle	M8x45	1
134	TS-1550071	Flat Washer	M10	2
135	TS-2361101	Spring Washer	M10	2
136	TS-1505051	Socket Head Cap Screw	M10x35	1
137	JWBS15-1137	Lower Blade Guide Assembly		1
138	JWBS15-1138	Trunnion Support Bracket Assembly		1
139	TS-1550061	Flat Washer	M8	4
140	TS-2361081	Spring Washer	M8	4
141	TS-1490041	Hex Cap Screw	M8x25	4
142	7015-48	Set Screw	M8x30	1
143	TS-1540061	Hex Nut	M8	1
144	JWBS15-1144	Bushing		1
145	IC290006	CE 3Phase Plug	P-551	1
146	JWBS15-196A	Strain Relief Fixed Plate		1
147	TS-2246102	Socket Head Button Screw	M6x10	4
148	JWBS-15M-1148	Switch Plate		1
149	TS-1540031	Nut	M5	2
150	JWBS-15M-1150	Temperature & Brake Cord (1PH)	0.75mm ² x5Cx1.6M	1
	JWBS-15T-1150	Temperature & Brake Cord (3PH)	0.75mm ² x7Cx1.6M	1
151	JWBS-15M-1151	Wire Connector	224-201	9
152	IC135506	Switch Cord	0.75mm ² x2Cx1.8M	1
153	NF040700	Hex. Nut w/Flange	M4	4
154	TS-1550021	Flat Washer	M4xØ8	2
155	130266	Door Latch Switch	AZD-S11	1
156	SP040610	Pan Head Bolt	M4x30	2
157	SP040200	Pan Head Bolt	M4x10	2
158	TS-2246102	Socket Head Button Screw	M6x10	2
159	TS-1550041	Flat Washer	M6xØ16	2
160	135379	Leaf Spring		1
161	TS-2248122	Socket Head Button Screw	M8x12	2
162	TS-1550061	Flat Washer	M8xØ18	2
163	135596	Cover Spring		1
164	NF081300	Hex. Nut w/Flange	M8	2
165	IC130366	Connect Cord (1PH)	1015x1Cx150mm	1

JWBS-15/18/20 Trunnion Support Bracket Assembly – Exploded View

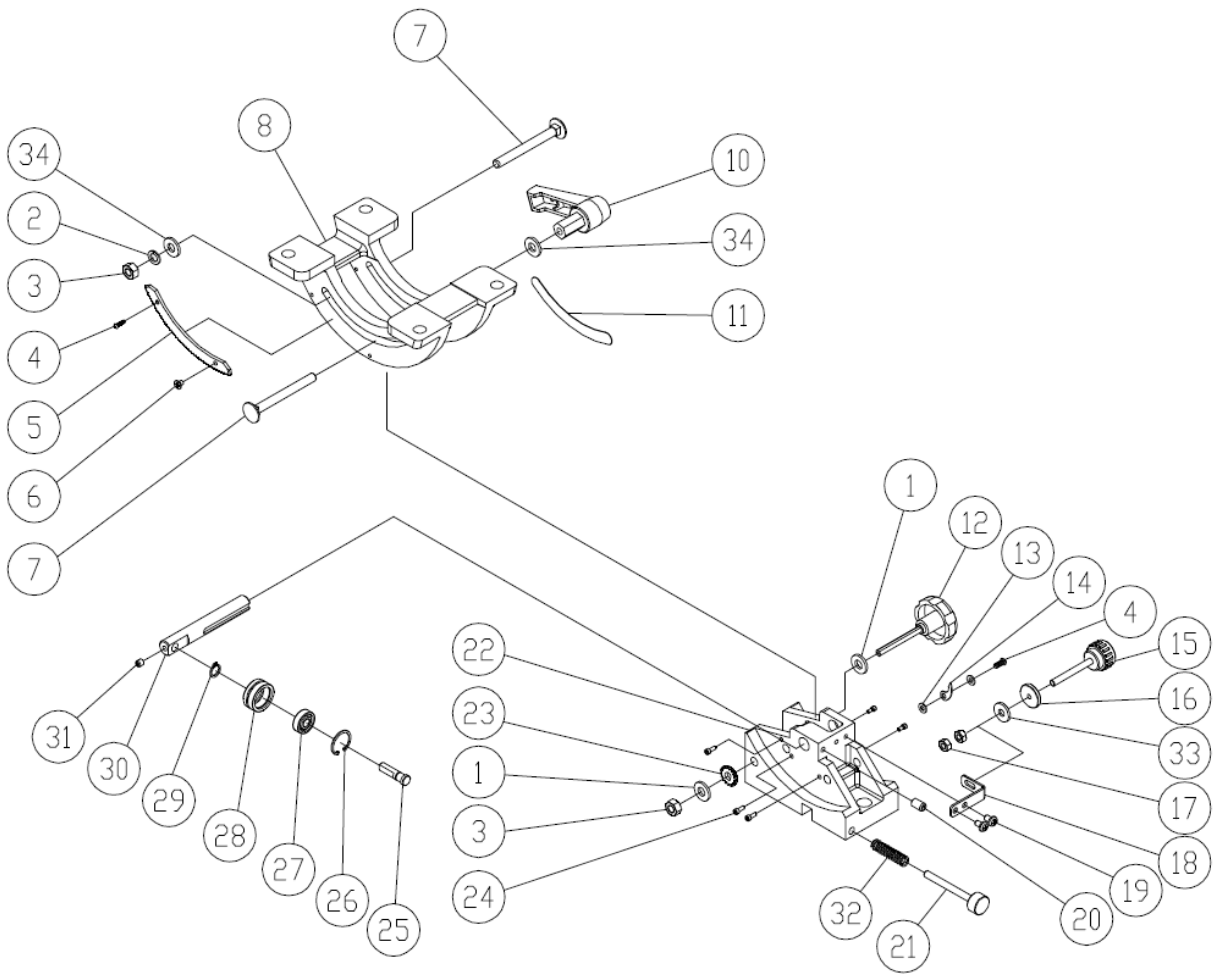

JWBS-15/18/20 Trunnion Support Bracket Assembly – Parts List

Index No	Part No	Description	Size	Qty
	JWBS15-1138A	Trunnion Support Bracket Assembly (#1 thru 34)		
1	TS-1550061	Flat Washer	M8 x Ø18	4
2	TS-2361081	Lock Washer	M8	1
3	TS-1541031	Nylon Lock Hex Nut	M8	2
4	TS-2171012	Phillips Pan Head Machine Screw	M4x6	2
5	PM1500-085-05	Gear Rack		1
6	TS-2284061	Phillips Flat Head Machine Screw	M4x6	1
7	JWBS15-1138-307	Carriage Bolt	M8x90	2
8	PM1500-085-08	Trunnion Block		1
10	JWBS15-1138-310	Lock Handle		1
11	PM1500-085-11	Tilt Scale		1
12	PM1500-085-12	Adjustment Knob Bolt		1
13	TS-1550021	Flat Washer	M4 x Ø8	2
14	PM1500-085-14	Angle Pointer		1
15	JWBS15-1138-315	Adjustment Knob Bolt	M6	1
16	PM1500-085-16	Locking Ring		1
17	TS-2311061	Hex Nut	M6	2
18	PM1500-085-18	Adjustment Plate		1
19	5712561	Phillips Pan Head Machine Screw	M5x8	2
20	PM1500-085-20	Set Screw		1
21	PM1500-085-21	Lock Knob		1
22	JWBS15-1138-322	Trunnion Support Bracket		1
23	PM1500-085-23	Gear		1
24	TS-2235061	Socket Head Cap Screw	M5x6	6
25	PM1500-085-25	Adjustment Shaft		1
26	PM1500-085-26	Retaining Ring	R22	1
27	BB-608ZZ	Ball Bearing	608ZZ	1
28	PM1500-085-28	Thrust Bearing Holder		1
29	PM1500-085-29	Retaining Ring	S8	1
30	JWBS15-1138-330	Adjustment Bar		1
31	TS-1523011	Socket Set Screw	M6x6	1
32	JWBS15-1138-332	Spring		1
33	TS-1550041	Flat Washer	M6 x Ø19	1
34	JWBS15-1138-334	Flat Washer	M8 x Ø23x5t	2

JWBS-15 Guide Bar Bracket Assembly – Exploded View

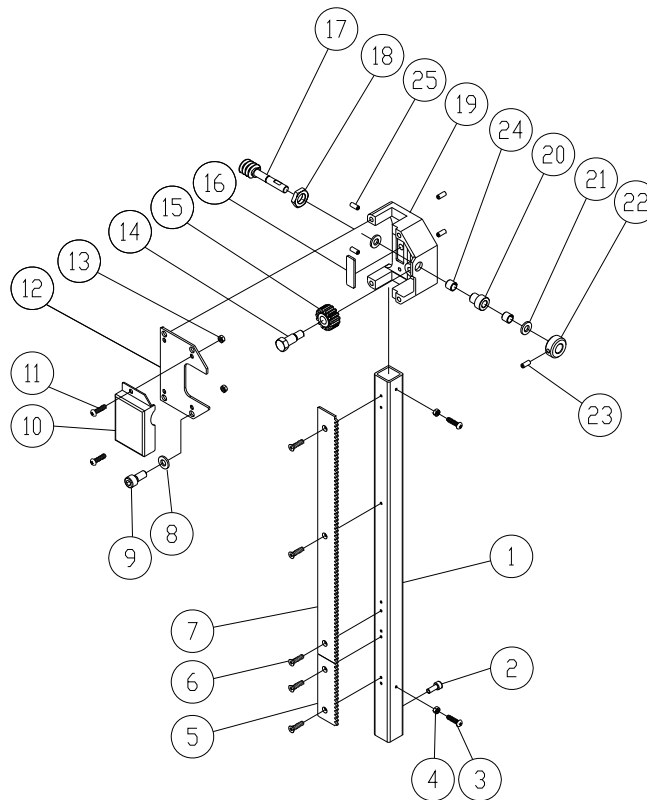

JWBS-15 Guide Bar Bracket Assembly – Parts List

Index No	Part No	Description	Size	Qty
	JWBS15-1120	Guide Bar Bracket Assembly (#1 thru 25)		
1	JWBS15-1120-401	Guide Bar		1
2	TS-1503021	Socket Head Cap Screw	M6x10	2
3	TS-1532032	Pan Head Screw	M4x10	2
4	TS-1540021	Nut	M4	2
5	PM1500-091-08	Guide Bar Rack (Short)		1
6	TS-2284081	Phillips Flat Head Machine Screw	M4x8	5
7	PM1500-091-20	Guide Bar Rack (Long)		1
8	TS-2361081	Spring Washer	M8	4
9	TS-1504031	Socket Head Cap Screw	M8x16	4
10	PM1500-091-04	Cover		1
11	TS-1534041	Pan Head Screw	M5x10	2
12	PM1500-091-09	Cover		1
13	TS-1540031	Hex Nut	M5	2
14	PM1500-091-10	Fixed Pin		1
15	PM1500-091-11	Gear		1
16	PM1500-091-12	Fixed Plate		1
17	PM1500-091-13	Worm Shaft		1
18	JWBS15-1120-418	Nut		1
19	PM1500-091-15	Guide Bracket		1
20	PM1500-091-18	Bushing		1
21	PM1500-091-25	Fiber Washer		2
22	PM1500-091-19	Collar		1
23	TS-1522011	Set Screw	M5x5	2
24	JWBS15-1120-424	Bushing Bearing	DU 10x12	2
25	JWBS15-1120-425	Plastic Nylon Set Screw	M7x10	4

JWBS-15 Upper Wheel Assembly – Exploded View

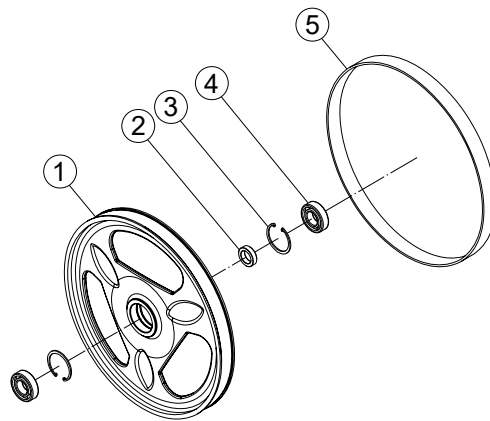

JWBS-15 Upper Wheel Assembly – Parts List

Index No	Part No	Description	Size	Qty
.....	PM1500-019	Upper Wheel Assembly (#1 thru 5).....		
1	PM1500-019-01	Upper Wheel.....	Dia. 15 inches.....	1
2	PM1500-019-02	Spacer.....		1
3	JWBS20QT-504	Retaining Ring.....	R52.....	2
4	BB-6205LLU	Ball Bearing.....	6205LLU.....	2
5	PM1500-019-05	Tire.....		1

JWBS-15 Lower Wheel Assembly – Exploded View

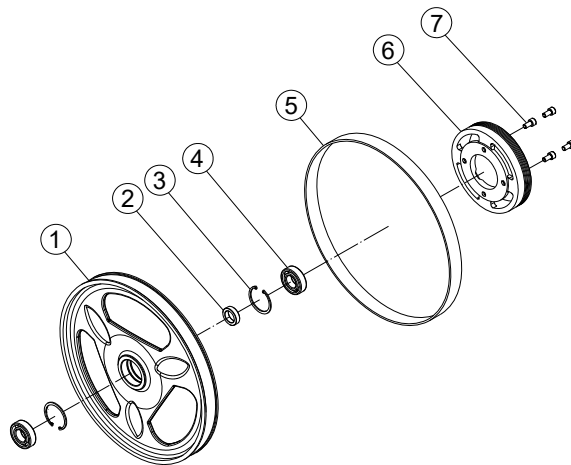

JWBS-15 Lower Wheel Assembly – Parts List

Index No	Part No	Description	Size	Qty
.....	PM1500-020	Lower Wheel Assembly (#1 thru 7).....		
1	PM1500-020-01	Lower Wheel.....	Dia. 15 inches.....	1
2	PM1500-019-02	Spacer.....		1
3	JWBS20QT-504	Retaining Ring.....	R52.....	2
4	BB-6205LLU	Ball Bearing.....	6205LLU.....	2
5	PM1500-019-05	Tire.....		1
6	PM1500-020-06	Drive Pulley.....		1
7	TS-1504031	Socket Head Cap Screw.....	M8x16.....	4

JWBS-15 Lower Blade Guide Assembly – Exploded View

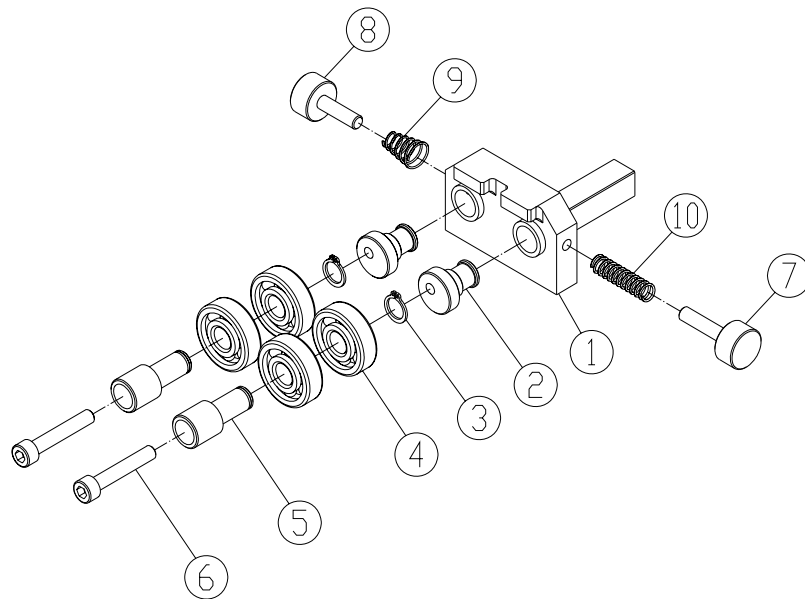

JWBS-15 Lower Blade Guide Assembly – Parts List

Index No	Part No	Description	Size	Qty
	JWBS15-1137	Lower Blade Guide Assembly (#1 thru 10)		
1	PM1500-096-01	Lower Blade Guide Support		1
2	PM1500-096-02	Eccentric Shaft		2
3	6286478	E Ring	S12	2
4	BB-6201ZZ	Ball Bearing	6201ZZ	4
5	PM1500-095-05	Knurled Knob		2
6	TS-1503081	Socket Head Cap Screw	M6x35	2
7	PM1500-095-16	Lock Knob		1
8	JWBS15-1137-508	Lock Knob		1
9	PM1800B-059-017	Cone Spring		1
10	JWBS15-1138-332	Spring		1

JWBS-15 Upper Blade Guide Assembly – Exploded View

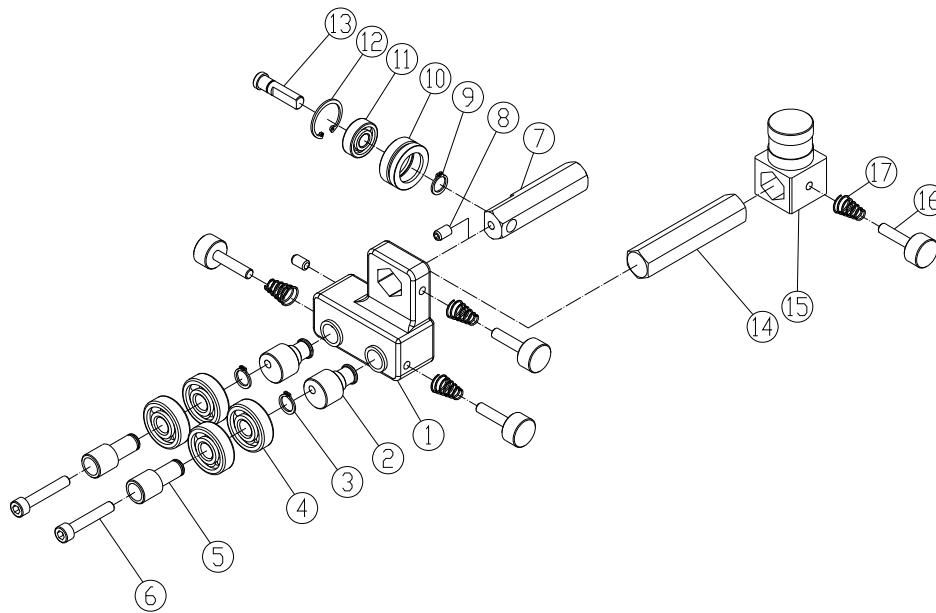

JWBS-15 Upper Blade Guide Assembly – Parts List

Index No	Part No	Description	Size	Qty
.....	JWBS15-1121	Upper Blade Guide Assembly (#1 thru 17)
1	PM1500-095-01	Upper Blade Guide Support	1
2	PM1500-095-02	Eccentric Shaft	2
3	6286478	Retaining Ring	S12	2
4	BB-6201ZZ	Ball Bearing	6201ZZ	4
5	PM1500-095-05	Knurled Knob	2
6	TS-1503081	Socket Head Cap Screw	M6x35	2
7	PM1500-095-07	Sleeve	1
8	TS-1523011	Set Screw	M6x6	2
9	PM1500-085-29	S Ring	S8	1
10	PM1500-085-28	Thrust Bearing Holder	1
11	BB-608ZZ	Ball Bearing	608ZZ	1
12	PM1500-085-26	Retaining Ring	R22	1
13	PM1500-085-25	Adjust Shaft	1
14	PM1500-095-14	Hex Post	1
15	PM1500-095-15	Upper Guide Support Block	1
16	PM1500-095-16	Lock Knob	1
17	PM1800B-059-017	Cone Spring	4

JWBS-15 Rip Fence Assembly – Exploded View

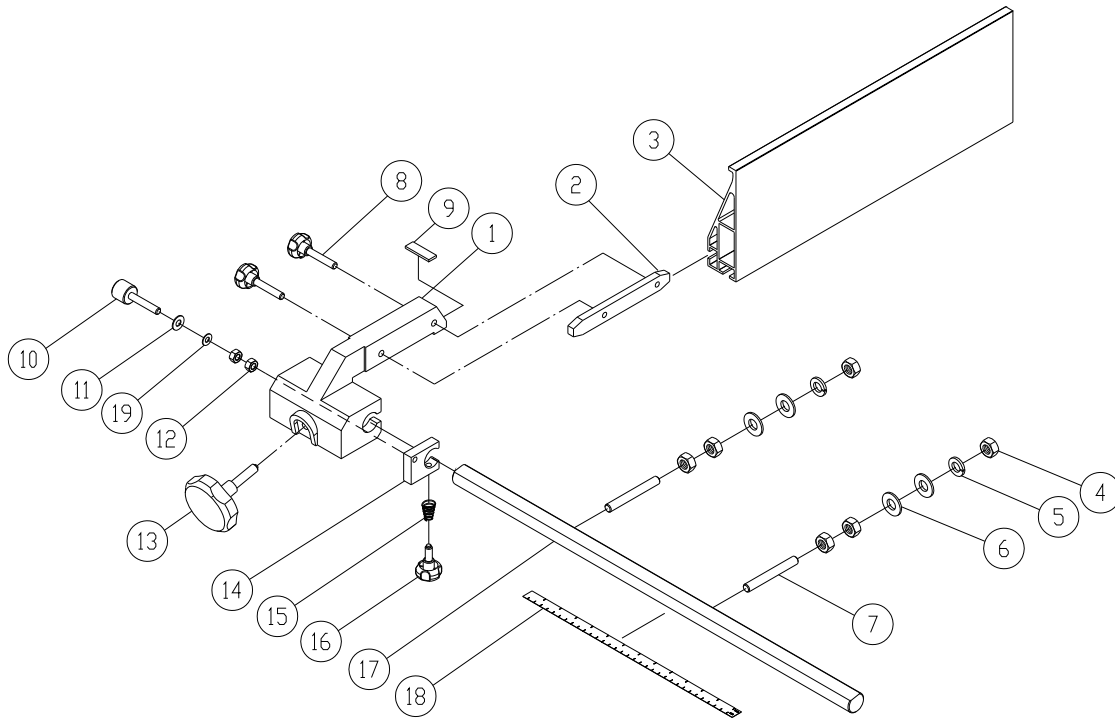

JWBS-15 Rip Fence Assembly – Parts List

Index No.	Part No.	Description	Size	Qty
	JWBS15-1123	Rip Fence Assembly (#1 thru 18)		
1	JWBS15-1123-201	Fence Body		1
2	JWBS15-1123-202	Lock Bar		1
3	JWBS15-1123-203	Fence, Aluminum	462mm	1
4	TS-2311101	Nut	M10	6
5	TS-2361101	Spring Washer	M10	2
6	TS-1550071	Flat Washer	M10	4
7	JWBS15-1123-207	Set Screw	M10x80	2
8	JWBS15-1123-208	Knob	M8x40	2
9	PM1500-107-10	Resistance Pad		1
10	JWBS15-1123-210	Adjustment Knob	M8x50	1
11	JWBS15-1123-211	Fiber Washer		1
12	TS-1540061	Nut	M8	2
13	JWBS15-1123-213	Knob	M8x40	1
14	JWBS15-1123-214	Locate Block		1
15	PM1800B-059-017	Cone Spring		1
16	JWBS15-1123-216	Knob	M6x14	1
17	JWBS15-1123-217	Fence Guide Rail	640mm	1
18	JWBS15-1123-218	Scale	350mm	1
19	JWBS15-1123-219	Wave Washer	Ø8x13 mm	1

JWBS-15/18/20 Miter Gauge Assembly – Exploded View

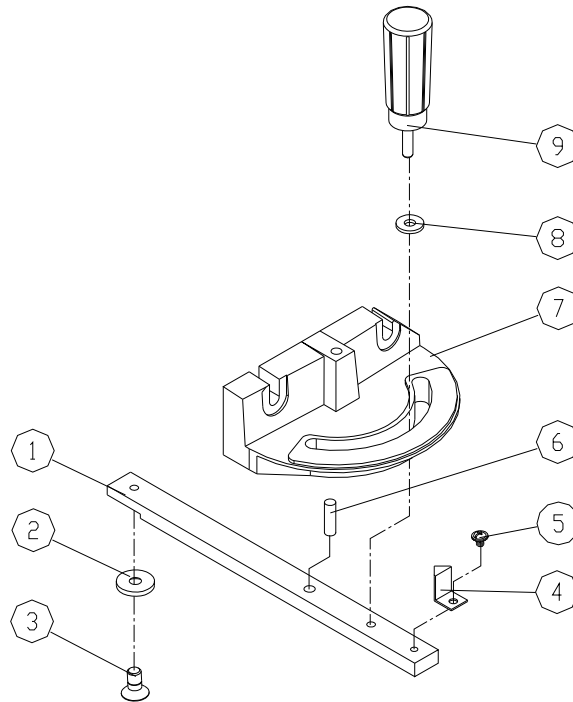

JWBS-15/18/20 Miter Gauge Assembly – Parts List

Index No	Part No	Description	Size	Qty
	JWBS15-1122	Miter Gauge Assembly (#1 thru 9)		1
1	JWBS15-1122-701	Guide Bar		1
2	JWBS15-1122-702	Guide Piece		1
3	JWBS15-1122-703	Countersunk Bolt	M6x6	1
4	JWBS15-1122-704	Pointer		1
5	PWBS14-251-5	Pan Head Flanged Screw	M5x8	1
6	JWBS15-1122-706	Steel Pin	Ø6x10mm	1
7	JWBS15-1122-707	Miter Gauge Body		1
8	JWBS15-1122-708	Nylon Washer		1
9	JWBS15-1122-709	Handle		1

Electrical Connections

JWBS-15-M.....714600M~230,50Hz

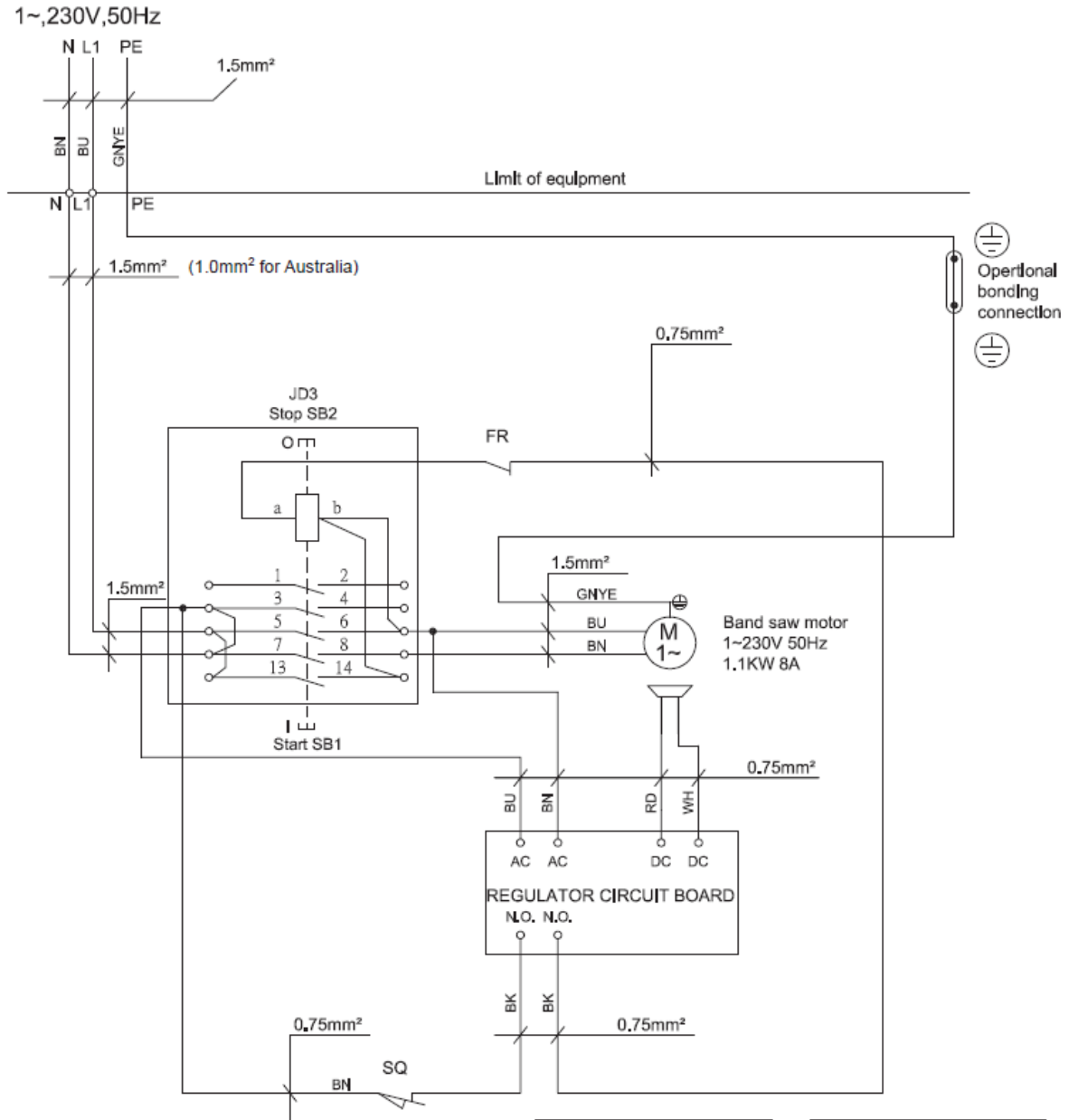

	colour of strands
BK	black
WH	white
BU	blue
RD	red
BN	brown
GNYE	green-yellow
OG	orange

	meaning of symbol
SB	switch
M	motor
KM	contact switch
FR	overload
SQ	limit switch
FR	temperature switch

Electrical Connections

JWBS-15T.....714650T3~400,50Hz

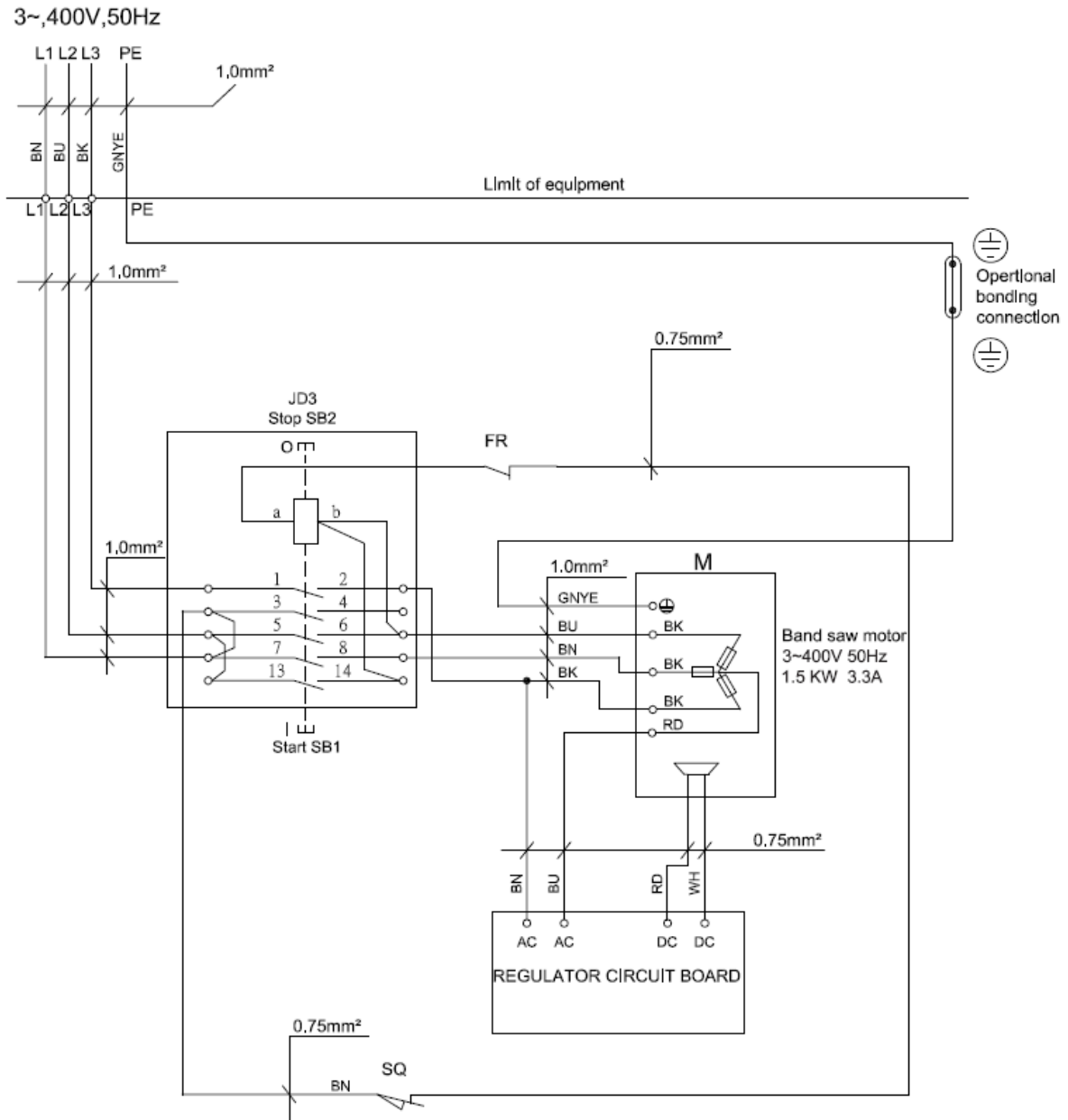

	colour of strands
BK	black
WH	white
BU	blue
RD	red
BN	brown
GNYE	green-yellow
OG	orange

	meaning of symbol
SB	switch
M	motor
KM	contact switch
FR	overload
SQ	limit switch
FR	temperature switch