

JET

JWDS-1632-M

DRUM SANDER

JWDS-1632-M....723520KM....1~230V, 50Hz

PARTS LIST

JPW (Tool) AG

Tämperlistrasse 5
CH-8117 Fällanden
Switzerland

Phone +41 44 806 47 48

Fax +41 44 806 47 58

www.jettools.com



P-723520KM 2017-1

JWDS-1632-M Head Assembly – Exploded View

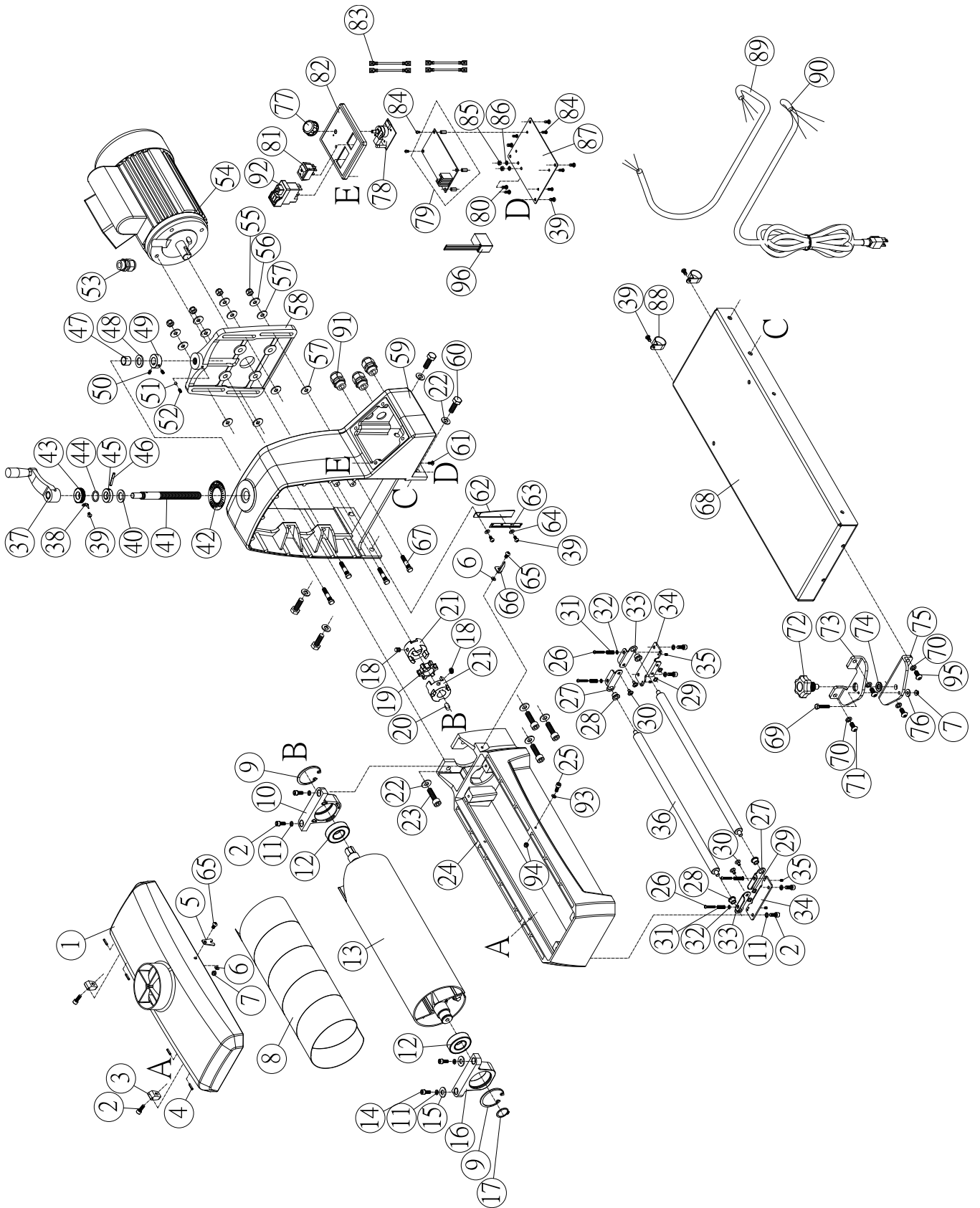

JWDS-1632-M Head Assembly – Parts List

Index No	Part No	Description	Size	Qty
1.....	JWDS1632-101	Dust Hood.....		1
2.....	TS-1503041.....	Socket Head Cap Screw	M6 x 1.0P x 16L	9
3.....	JWDS1632-103	Drum Carriage Hinge		2
4.....	40317-15	Spring Pin.....	3 x 14L	4
5.....	JWDS1632-105E	Locking Plate.....		1
6.....	F002636.....	Flat Washer, BO	6 x 12 x 1T	2
7.....	F001753.....	Nyloc Nut BO	M6 x 1.0P	2
8.....	JWDS1632-108	Abrasive.....		1
9.....	PM2244-114	Retainer Ring (Re:13A)	RTW-52	2
10.....	JWDS1632-110	Inboard Bearing Housing (Re:13A)		1
11.....	TS-2361061.....	Lock Washer	M6.....	9
12.....	PM2244-115	Ball Bearing (Re:13A).....	6205VV.....	2
13.....	JWDS1632-113	Drum (Re:13A).....		1
13A	JWDS1632-113A.....	Drum Assembly (includes #2, 9-21).....		
14.....	F005384.....	Socket Head Cap Screw	M6 x 1.0P x 25L	2
15.....	JWDS1632-115	Flat Washer.....	6.5 x 19 x 3t	2
16.....	JWDS1632-116	Outboard Bearing Housing (Re:13A)		1
17.....	PM2244-112	Retainer Ring (Re:13A)	STW-25	1
18.....	F010408.....	Socket Set Screw	M8 x 1.25P x 10L	2
19.....	PM2244-139	Rubber Cushion (Re:13A)		1
20.....	JWDS1632-120	Key (Re:13A)	8 x 7 x 20L	2
21.....	PM2244-138	Coupling (Re:13A).....		2
22.....	F002643.....	Flat Washer.....	10 x 20 x 2.0T	8
23.....	F005430.....	Socket Head Cap Screw	M10 x 1.5P x 35L	4
24.....	JWDS1632-124	Drum Carriage		1
25.....	JWDS1632-125E	Socket Head Cap Screw	M5 x 0.5P x 30L.....	1
26.....	JWDS1632-126	Phillips Round Head Screw	M4 x 0.7P x 25L	4
27.....	PM2244-129	Left Tension Roller Suspension Bracket.....		2
28.....	PM2244-130	Oilite Bushing.....		4
30.....	PM2244-132	Shoulder Screw.....		4
29.....	TS-1550041.....	Flat Washer.....	6.5 x 13 x 1T	4
31.....	PM2244-125	Compression Spring.....		4
32.....	TS-1550021.....	Flat Washer.....	4.2 x 8 x 0.8T	4
33.....	PM2244-131	Right Tension Roller Suspension Bracket		2
34.....	PM2244-128	Tension Roller Bracket.....		2
35.....	JWDS1632-135	Socket Head Set Screw w/LocTite	M4 x 0.7P x 5L	4
36.....	JWDS1632-136	Tension Roller		2
37.....	JWDS1632-137	Crank Handle		1
38.....	JWDS1632-138	Pointer		1
39.....	JWDS1632-139	Phillips Round Head Screw	M5 x 0.8P x 8L	9
40.....	JWDS1632-140	Oilite Washer.....		1
41.....	JWDS1632-141	Height Adjusting Screw.....		1
42.....	JWDS1632-142	Incremental Depth Scale		1
43.....	JWDS1632-143	Dial.....		1
44.....	JWDS1632-144	O-Ring.....	P11	1
45.....	JWDS1632-145	Collar		1
46.....	JWDS1632-146	Spring Pin.....	4 x 30L	1
47.....	JWDS1632-147	Oilite Bushing.....		1
48.....	JWDS1632-148	Nylon Washer		1
49.....	JWDS1632-149	Collar		1
50.....	TS-1523031.....	Socket Head Set Screw	M6 x 1.0P x 10L.....	2
51.....	PM2244-184	PU Block.....		1
52.....	5302731.....	Socket Head Set Screw	M8 x 1.25P x 6L	1
53.....	JWDS1632-153E	Strain Relief	PG 13.5.....	1
54.....	JWDS1632-154E	Motor.....	1.5HP, 230V, 50Hz	1

Index No	Part No	Description	Size	Qty
	JWDS1632-154SC	Starting Capacitor (not shown)		1
	JWDS1632-154SCC	Starting Capacitor Cover (not shown)		1
	JWDS1632-154FC	Fan Cover (not shown)		1
	JWDS1632-154CF	Cooling Fan (not shown)		1
55	TS-1541031	Nyloc Nut	M8 x 1.25P	4
56	TS-1550061	Flat Washer	8.2 x 23 x 2T	4
57	JWDS1632-157	Oilite Washer		8
58	JWDS1632-158	Motor Plate		1
59	JWDS1632-159	Motor Shroud		1
60	TS-1491041	Hex Cap Screw	M10 x 1.5P x 30L	4
61	JWDS1632-161	Self Tapping Screw	M4 x 15L	4
62	JWDS1632-162	Depth Scale Bracket (includes #63)		1
63	JWDS1632-163	Depth Scale		1
64	TS-1550031	Flat Washer	5.1 x 12 x 1T	2
65	TS-1534032	Phillips Pan Hd Machine Screw	M6 x 1.0P x 10L	1
66	JWDS1632-166	Pointer		1
67	JWDS1632-167	Stud		4
68	JWDS1632-168	Base		1
69	TS-1482061	Hex Cap Screw	M6 x 1.0P x 30L	1
70	TS-2361081	Lock Washer	M8	4
71	TS-2248162	Socket Head Button Screw	M8 x 1.25 x 16L	2
72	JWDS1632-172	Knob		1
73	JWDS1632-173	Parallel Adjust Moving Bracket		1
74	JWDS1632-174	Oilite Washer		1
75	JWDS1632-175	Parallel Adjust Fixed Bracket		1
76	TS-1550041	Flat Washer	6.5 x 19 x 2T	1
77	PM2244-196	Knob		1
78	JWDS1632-178	Potentiometer		1
79	JWDS1632-179E	Circuit Board		1
80	TS-1533042	Phillips Pan Hd Machine Screw	M5 x 0.8P x 12L	2
81	JWDS1632-181E	On/Off Switch		1
82	JWDS1632-182E	Control Panel		1
83	JWDS1632-183	Internal Connection Cable		1
84	TS-1531012	Phillips Pan Hd Machine Screw	M3 x 0.5P x 5L	8
85	TS-1540031	Hex Nut	M5 x 0.8P	2
86	F002097	Lock Washer, Ext. Tooth	M5	2
87	JWDS1632-187	Circuit Board Holder		1
88	JWDS1632-188E	Cable Management	ACC-5-B	2
89	JWDS1632-189E	Motor Cable		1
90	JWDS1632-190E	Power Cable		1
91	JWDS1632-191E	Strain Relief	M20	2
92	JWDS1632-192E	Power Switch		1
93	TS-1550031	Flat Washer	5 x 12 x 1T	1
94	TS-1541011	Nyloc Nut	M5 x 0.8P	1
95	TS-2248202	Socket Head Button Screw	M8 x 1.25 x 20L	2
96	JWDS1632-196E	EMC Filter		1
	JWDS1632-194	JET Logo (not shown)	113x47mm	1
	JWDS1632-195E	Motor Label (not shown)		1
	JWDS1632-196E	Control Panel Label (not shown)		1
	JWDS1632-197E	Left Parallel Adjust Label (not shown)		1
	JWDS1632-198E	Right Parallel Adjust Label (not shown)		1
	LM000237E	ID Label, JWDS-1632 (not shown)		1
	LM000238E	Warning Label (not shown)		1

JWDS-1632-M Conveyor Table Assembly – Exploded View

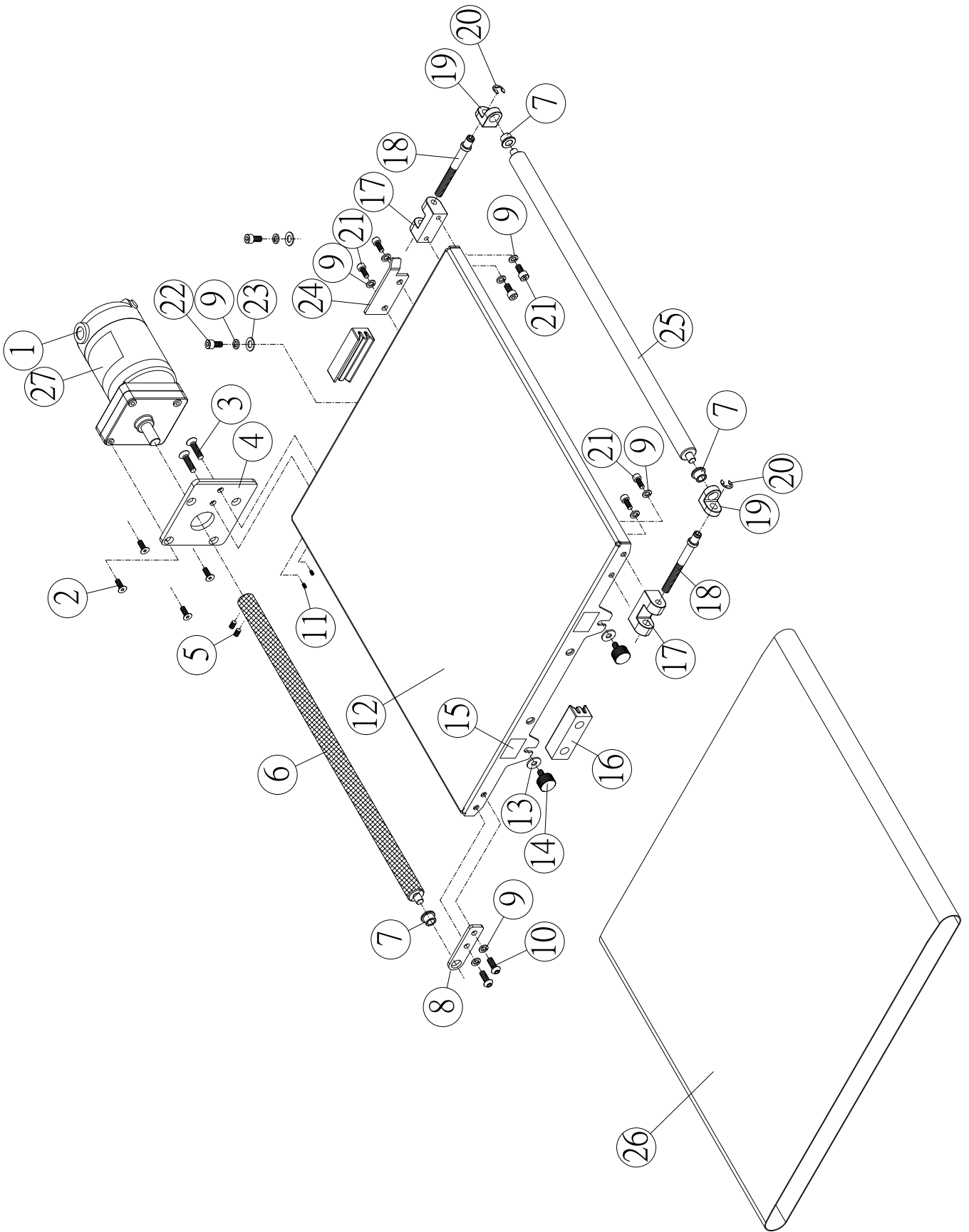

JWDS-1632-M Conveyor Table Assembly – Parts List

Index No	Part No	Description	Size	Qty
1	JWDS1632-201E	Belt Motor		1
2	F010839	Socket Head Flat Screw	#10-32 x 1/2" L	4
3	F010985	Socket Head Flat Screw	M6 x 1.0P x 35L	2
4	JWDS1632-204	Belt Motor Plate		1
5	TS-1522011	Socket Head Set Screw	M5 x 0.8P x 5L	2
6	JWDS1632-206	Drive Roller		1
7	PM2244-130	Oilite Bushing		3
8	JWDS1632-208	Drive Roller Bracket		1
9	TS-2361061	Lock Washer	M6	8
10	TS-2246162	Socket Head Button Screw	M6 x 1.0P x 16L	2
11	TS-1521021	Socket Head Set Screw	M4 x 0.7P x 5L	2
12	JWDS1632-212	Conveyor Table		1
13	TS-1550041	Flat Washer	6.4 x 19 x 1.5T	2
14	JWDS1632-214	Table Lock Knob		2
15	LM000236	Caution Label – Table Lock		2
16	PM2244-213	Tracker Kit (set of 2)		2
17	JWDS1632-217	Bracket		2
18	JWDS1632-218	Adjusting Rod		2
19	JWDS1632-219	Driven Roller Bracket		2
20	JWDS1632-220	Retaining Ring	ETW-7	2
21	TS-1503031	Socket Head Cap Screw	M6 x 1.0P x 12L	6
22	TS-1503041	Socket Head Cap Screw	M6 x 1.0P x 16L	2
23	TS-0680021	Flat Washer	1/4" x 16 x 2T	2
24	JWDS1632-224	Guide Plate		1
25	JWDS1632-225	Driven Roller		1
26	JWDS1632-226	Conveyor Belt		1
27	JWDS1632-227E	Belt Motor Label		1

JWDS-1632-M Open Stand Assembly – Exploded View

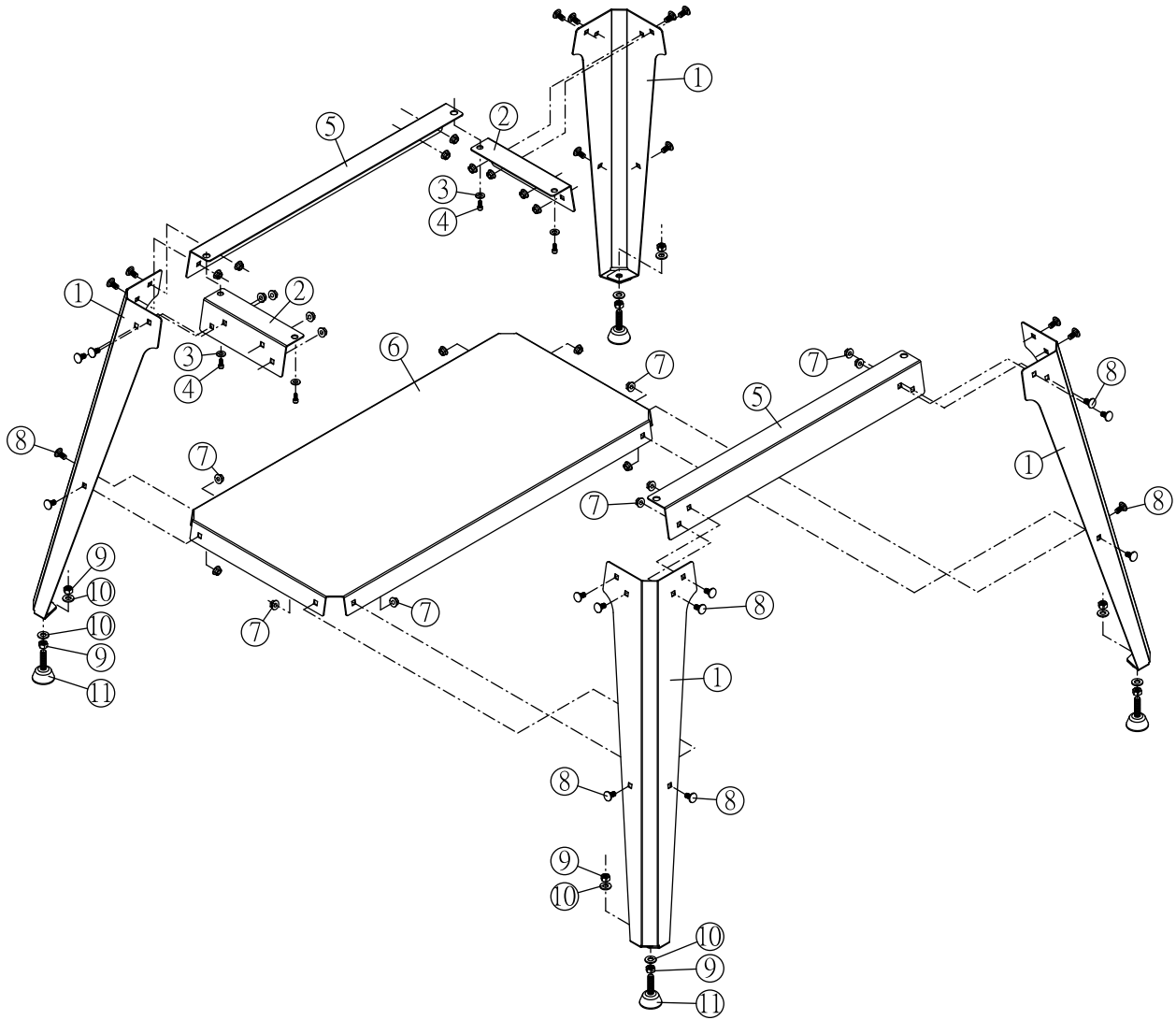

JWDS-1632-M Open Stand Assembly – Parts List

Index No	Part No	Description	Size	Qty
.....	723520S.....	Open Stand Assembly (includes #1-11).....	1
1.....	JWDS1632-301	Leg	4
2.....	JWDS1632-302	Short Rail	2
3.....	TS-1550061.....	Flat Washer	8.3 x 18 x 1.5T.....	4
4.....	TS-1504031.....	Socket Head Cap Screw	M8 x 1.25P x 16L	4
5.....	JWDS1632-305	Long Rail	2
6.....	JWDS1632-306	Shelf.....	1
7.....	JWDS1632-307	Flange Lock Nut.....	M8 x 1.25P	24
8.....	JWDS1632-308	Carriage Bolt.....	M8 x 1.25P x 16L.....	24
9.....	TS-1540071.....	Hex Nut	M10 x 1.5P.....	8
10.....	TS-1550071.....	Flat Washer	10 x 20 x 2.0T.....	8
11.....	JWDS1632-311	Leveling Foot	4

JWDS-1632-M Infeed and Outfeed Tables (OPTIONAL) – Exploded View

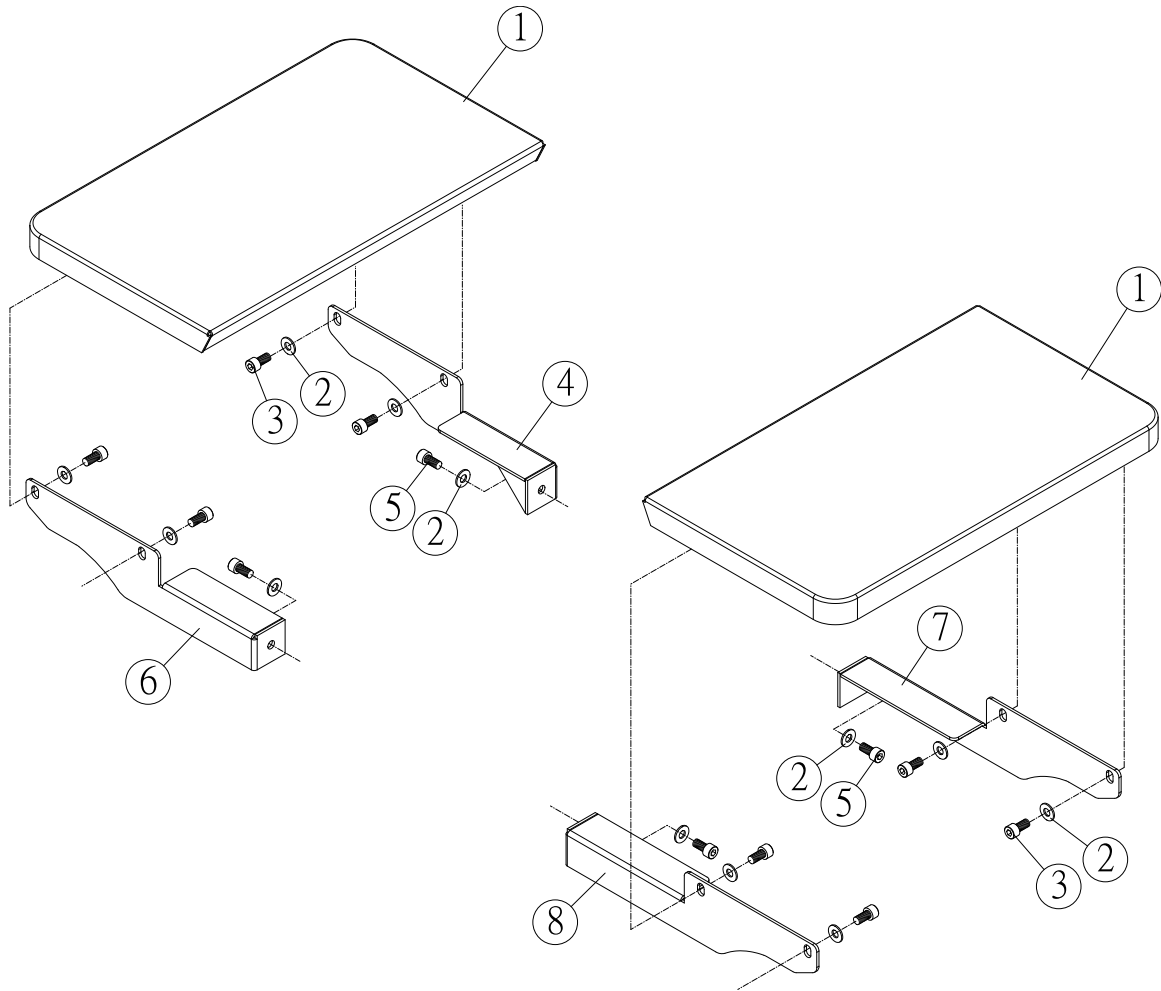

JWDS-1632-M Infeed and Outfeed Tables (OPTIONAL) – Parts List

Index No	Part No	Description	Size	Qty
.....	723521.....	Infeed/Outfeed Tables (includes #1-8)
1.....	JWDS1632-401	Extension Table	2
2.....	TS-1550061.....	Flat Washer	8.3 x 18 x 1.5T.....	12
3.....	TS-1504031.....	Socket Head Cap Screw	M8 x 1.25P x 16L	4
4.....	JWDS1632-404	Rear-Right Table Bracket.....	1
5.....	TS-1504021.....	Socket Head Cap Screw	M8 x 1.25P x 12L.....	8
6.....	JWDS1632-405	Rear-Left Table Bracket.....	1
7.....	JWDS1632-406	Front-Right Table Bracket	1
8.....	JWDS1632-407	Front-Left Table Bracket.....	1

JWDS-1632-M.....723520KM.....1~230V, 50Hz

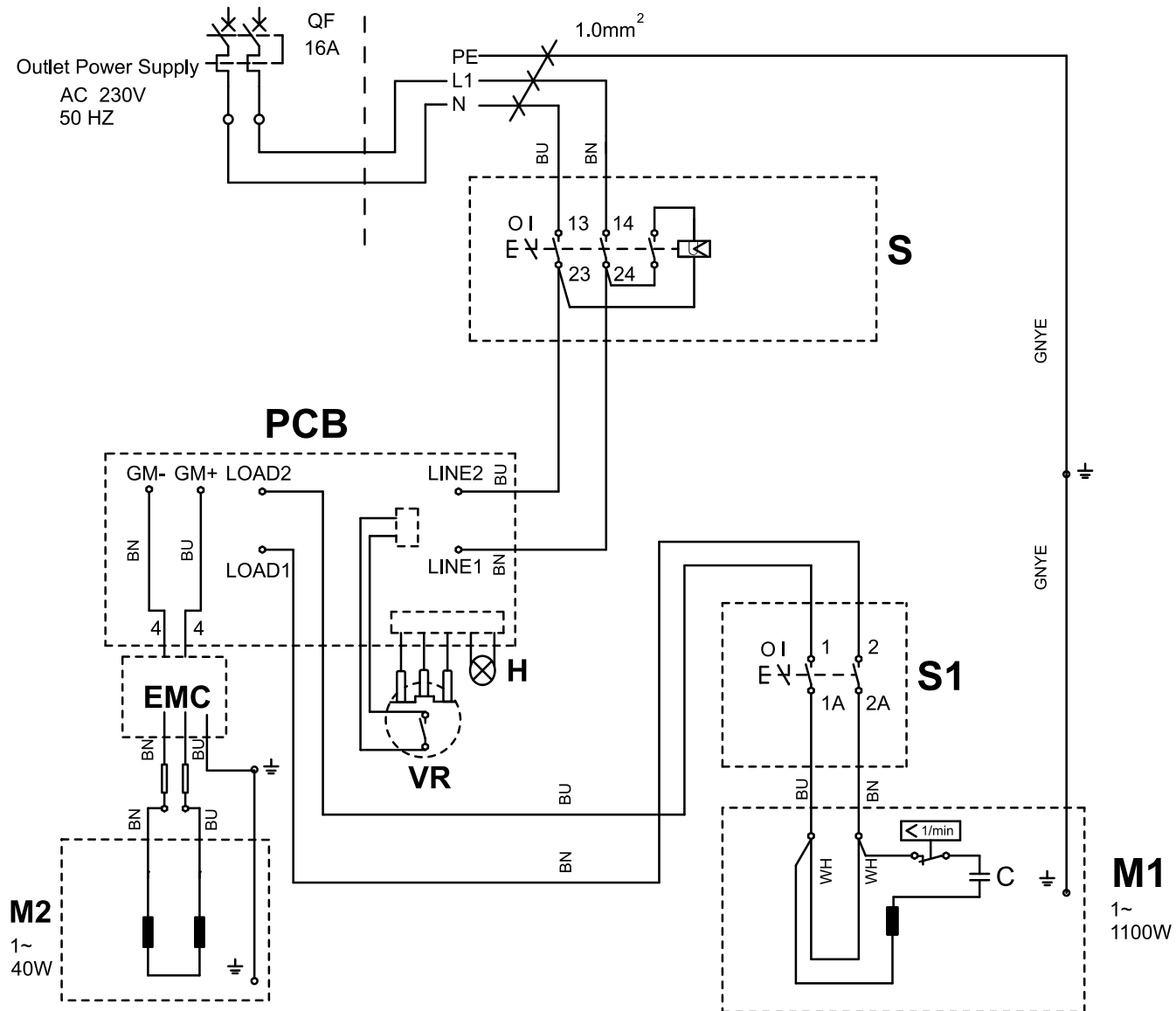

	colour of strands	Litzenfarben	couleur des cordons
BK	black	schwarz	noir
WH	white	weiß	blanc
BU	blue	blau	bleu
YE	yellow	gelb	jaune
RD	red	rot	rouge
BN	brown	braun	brun
GY	grey	grau	gris
GNYE	green-yellow	grün-gelb	vert-jaune
OG	orange	orange	orange
VT	violet	violett	violet

	meaning of symbol	Bedeutung der Zeichen	interprétation
M1	motor	Motor	moteur
M2	motor	Motor	moteur
S	switch	Schalter	interrupteur
S1	switch	Schalter	interrupteur
C	condenser	Kondensator	condensateur
VR	potentiometer	Potentiometer	potentiomètre
EMC	filter	Filter	filtre
PCB	circuit board	Leiterplatte	carte circuit
H	indication light	Anzeigelicht	La lumière d'indication