



JWDS-2244OSC-M DRUM SANDER

JWDS-2244OSC-M...723544OSCKM
1~230V, 50Hz

PARTS LIST

JPW (Tool) AG
Ackerstrasse 45
CH-8610 Uster
Switzerland

www.jettools.com

P-723544OSCKM 2019-5



JWDS-22440SC-M Head Assembly – Exploded View

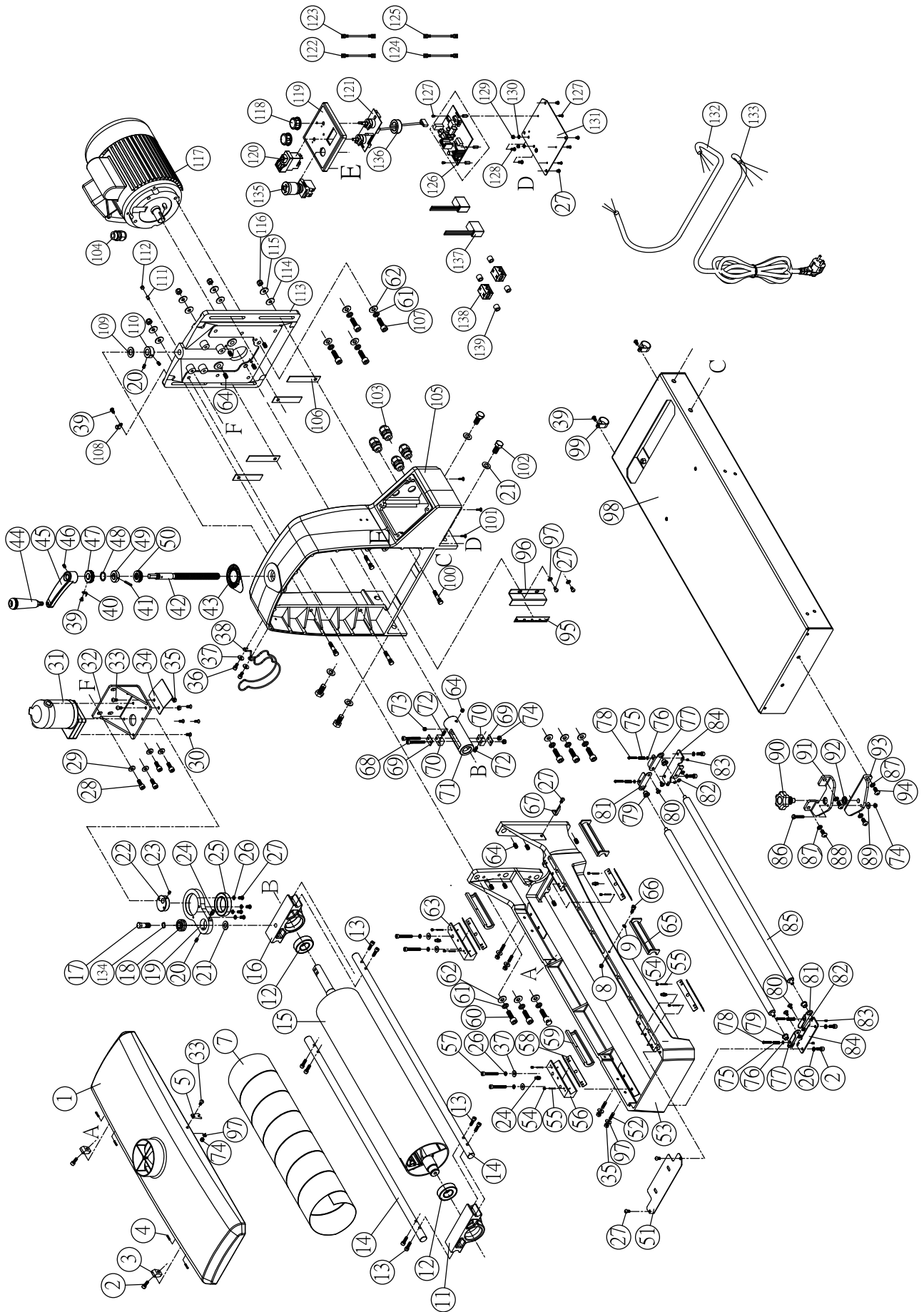

JWDS-2244OSC-M Head Assembly – Parts List

Index No	Part No	Description	Size	Qty
1	JWDS2244OSC-101	Dust Hood		1
2	JWDS2244-102	Socket Head Cap Screw	M6-1.0P x 16L	6
3	JWDS1632-103	Drum Carriage Hinge		2
4	40317-15	Spring Pin	3 x 14L	4
5	JWDS1632-105E	Locking Plate		1
7	JWDS2244-107	Abrasive	#80 Grit	1
8	TS-1541011	Nylon Lock Hex Nut	M5-0.8P	1
9	TS-1550031	Flat Washer	5.1 x 12 x 1T	1
11	JWDS2244OSC-111	Outboard Bearing Housing (Re:15A)		1
12	PM2244-115	Ball Bearing (Re:15A)	6205VV	2
13	TS-1503061	Socket Head Cap Screw (Re:15A)	M6-1.0P x 25L	8
14	PM2244-115-114	Guide Bar (Re:15A)		2
15	JWDS2244OSC-115	Drum (Re:15A)		1
15A	JWDS2244OSC-115A	Drum Assembly (includes #11-16)		1
16	JWDS2244OSC-116	Inboard Bearing Housing (Re:15A)		1
17	JWDS2244OSC-117	Shoulder Screw		1
18	JWDS2244OSC-118	Spherical Bearing	PB12(SB)	1
19	JWDS2244OSC-119	Linking Plate		1
20	TS-1523031	Socket Head Set Screw	M6-1.0P x 10L	3
21	TS-2360121	Flat Washer	12 x 23 x 2T	5
22	JWDS2244OSC-122	Cam		1
23	F010454L	Soc Set Screw CPP w/thrdlckr	M6-1.0P x 15L	1
24	JWDS2244OSC-124	Grease Fitting	M6	5
25	BB-6908ZZ	Ball Bearing	6908ZZ	1
26	TS-2361061	Lock Washer	M6	8
27	TS-1534032	Phillips Pan Hd Machine Screw	M6-1.0P x 10L	16
28	TS-1504041	Socket Head Cap Screw	M8-1.25P x 20L	4
29	TS-1550061	Flat Washer	8 x 18 x 2T	4
30	JWDS2244OSC-130	Socket Head Flat Screw	M5*0.8P*12L	4
31	JWDS2244OSC-131E	Oscillating Motor		1
	JWDS1632-201-1	Carbon Brush (not shown)		2
32	JWDS2244OSC-132	Oscillating Motor Plate		1
33	TS-1534042	Phillips Pan Hd Machine Screw	M6-1.0P x 12L	3
34	JWDS2244OSC-134	Safety Guard		1
35	TS-2311061	Hex Nut	M6-1.0P	6
36	TS-1503031	Socket Head Cap Screw	M6-1.0P x 12L	2
37	JWDS2244-153	Flat Washer	6.4 x 16 x 1.6T	6
38	JWDS2244-154	Hose Hanger		1
39	JWDS1632-139	Phillips Round Head Screw	M5-0.8P x 8L	4
40	JWDS1632-138	Pointer		1
41	JWDS1632-146	Spring Pin	4 x 30L	1
42	JWDS2244-158	Height Adjusting Screw		1
43	JWDS2244-159E	Incremental Depth Scale		1
44	JWDS2244-160	Handle Assembly		1
45	JWDS2244-162	Crank		1
46	TS-1523031	Socket Head Set Screw	M6-1.0P x 10L	1
47	JWDS1632-143	Dial		1
48	JWDS1632-144	O-Ring	P11	1
49	JWDS1632-145	Collar		1
50	BB-51103	Thrust Bearing	17 x 30 x 9T	1
51	JWDS2244OSC-151	Safety Guard		1
52	TS-1523061	Socket Head Set Screw	M6-1.0P x 20L	4
53	JWDS2244OSC-153	Drum Carriage		1
54	6286492	Socket Head Set Screw	M6-1.0P x 5L	8
55	JWDS2244OSC-155	Spring Pin	2.5 x 20L	8
56	JWDS2244OSC-156	outboard Guide Block		1

Index No	Part No	Description	Size	Qty
57	TS-1503101	Socket Head Cap Screw	M6-1.0P x 45L	4
58	JWDS2244OSC-158	Gib		8
59	JWDS2244OSC-159	Seal Cover for Removable Guide Block		2
60	TS-1505061	Socket Head Cap Screw	M10-1.5P x 40L	6
61	TS-2361101	Lock Washer	M10	10
62	TS-1550071	Flat Washer	10 x 25 x 3T	10
63	JWDS2244OSC-163	Inboard Guide Block		1
64	F010408L	Soc Set Screw CPP w/thrdlckr	M8-1.25P x 10L	10
65	JWDS2244OSC-165	Seal Cover for Integrated Guide Block		2
66	TS-1502071	Socket Head Cap Screw	M5-0.8P x 30L	1
67	JWDS1632-166	Pointer		1
68	JWDS2244OSC-168	Socket Head Cap Screw, Partial Thrd	M6-1.0P x 55L	2
69	JWDS2244OSC-169	Drive Glider Plate		2
70	JWDS2244OSC-170	Drive Glider		2
71	JWDS2244OSC-171	Coupling		1
72	JWDS2244OSC-172	Ball Plunger		2
73	F010455L	Soc Set Screw CPP w/thrdlckr	M8-1.25P x 6L	1
74	F001753	Nyloc Nut BO	M6-1.0P	4
75	PM2244-125	Compression Spring		4
76	TS-1550021	Flat Washer	4.2 x 8 x 0.8T	4
77	PM2244-131	Right Tension Roller Suspension Bracket		2
78	JWDS1632-126	Phillips Round Head Screw	M4-0.7P x 25L	4
79	PM2244-130	Oilite Bushing		4
80	PM2244-132	Shoulder Screw		4
81	PM2244-129	Left Tension Roller Suspension Bracket		2
82	63049	Wave Washer	WW-6	4
83	F010386L	Soc Set Screw CPP w/thrdlckr	M4-0.7P x 8L	4
84	PM2244-128	Tension Roller Bracket		2
85	JWDS2244OSC-185	Tension Roller		2
86	TS-1482061	Hex Cap Screw	M6-1.0P x 30L	1
87	TS-2361081	Lock Washer	M8	4
88	TS-2248162	Socket Head Button Screw	M8-1.25P x 16L	2
89	TS-1550041	Flat Washer	6.5 x 19 x 2T	1
90	JWDS1632-172	Knob		1
91	JWDS1632-173	Parallel Adjust Moving Bracket		1
92	JWDS1632-174	Oilite Washer		1
93	JWDS1632-175	Parallel Adjust Fixed Bracket		1
94	TS-2248202	Socket Head Button Screw	M8-1.25P x 20L	2
95	JWDS2244-168E	Depth Scale		1
96	JWDS2244OSC-196	Depth Scale Plate		1
97	TS-1550041	Flat Washer	6 x 12 x 1T	7
98	JWDS2244OSC-198	Base		1
99	JWDS1632-188E	Cable Management	ACC-5-B	2
100	JWDS2244-167	Stud		4
101	JWDS2244-172	Self Tapping Screw	M4 x 20L	4
102	TS-1492021	Hex Cap Screw	M12-1.75P x 30L	4
103	JWDS2244-177E	Strain Relief	M20SAL-2	2
104	JWDS1632-153E	Strain Relief	PG 13.5	3
105	JWDS2244OSC-1105	Motor Shroud		1
106	JWDS2244-176	Oilite Plate		4
107	F005430	Socket Head Cap Screw	M10-1.5P x 35L	4
108	JWDS2244OSC-1108	Cable Tie	ACC-2.5 (7.8mm)	1
109	JWDS1632-148	Nylon Washer		1
110	JWDS1632-149	Collar		1
111	PM2244-184	PU Block		1
112	5302731	Socket Head Set Screw	M8-1.25P x 6L	1
113	JWDS2244OSC-1113	Motor Plate		1
114	JWDS1632-157	Oilite Washer		4
115	TS-1550061	Flat Washer	8.2 x 23 x 2T	4

Index No	Part No	Description	Size	Qty
116	TS-1541031	Nylon Lock Hex Nut	M8-1.25P	4
117	JWDS1836-154E	Motor	"1.75HP, 230V, 50Hz"	1
	JWDS1632-154SC	Starting Capacitor (not shown)	300MFD 125VAC	1
	JWDS1632-154SCC	Starting Capacitor Cover (not shown)		1
	JWDS1836-154RC	Running Capacitor (not shown)	50µF 250VAC	1
	JWDS1632-154FC	Fan Cover (not shown)		1
	JWDS1632-154CF	Cooling Fan (not shown)		1
118	PM2244-196	Knob		2
119	JWDS2244OSC-1119E	Control Panel (includes label)		1
120	JWDS2244-193E	Switch		1
121	JWDS2244OSC-1121E	Potentiometer w/cords & ferrite core		1
122	JWDS2244-197E	Internal Connection Cable (Brown)	ST 12AWG x 1C x 15cm	1
123	JWDS2244-198E	Internal Connection Cable (Blue)	ST 12AWG x 1C x 15cm	1
124	JWDS2244OSC-1124E	Internal Connection Cable (Brown)	ST 16AWG x 1C x 15cm	2
125	JWDS2244OSC-1125E	Internal Connection Cable (Blue)	ST 16AWG x 1C x 15cm	2
126	JWDS2244OSC-1126E	Circuit Board		1
127	TS-1531012	Phillips Pan Hd Machine Screw	M3-0.5P x 5L	8
128	TS-1533042	Phillips Pan Hd Machine Screw	M5-0.8P x 12L	2
129	TS-1540031	Hex Nut	M5-0.8P	2
130	F002097	Lock Washer, Ext. Tooth	M5	2
131	JWDS2244-1102	Circuit Board Holder		1
132	JWDS2244-1103E	Motor Cable		1
133	JWDS1632-190E	Power Cable		1
134	JWDS2244OSC-1134	Wave Washer	WW-12	1
135	JWDS2244-1107E	Emergency Stop		1
136	JWDS2244-1108E	Ferrite Core for Potentiometer		1
137	JWDS1632-196E	EMC Filter		2
138	JWDS2244-1109E	Ferrite Core for Belt Motor		2
139	JWDS2244OSC-139E	Foam Pad		4
	JWDS2244-1105E	Motor Label (not shown)		1
	LM000360E	Oscillating Motor Label (not shown)		1
	LM000358E	ID Label, JWDS-2244OSC (not shown)		1
	JET-113	JET Logo (not shown)	113x47mm	1
	LM000359E	Control Panel Label (not shown)		1
	JWDS1632-197	Left Parallel Adjust Label (not shown)		1
	JWDS1632-198	Right Parallel Adjust Label (not shown)		1
	LM000238E	Warning Label (not shown)		1

JWDS-2244OSC -M Conveyor Table Assembly + Exploded View

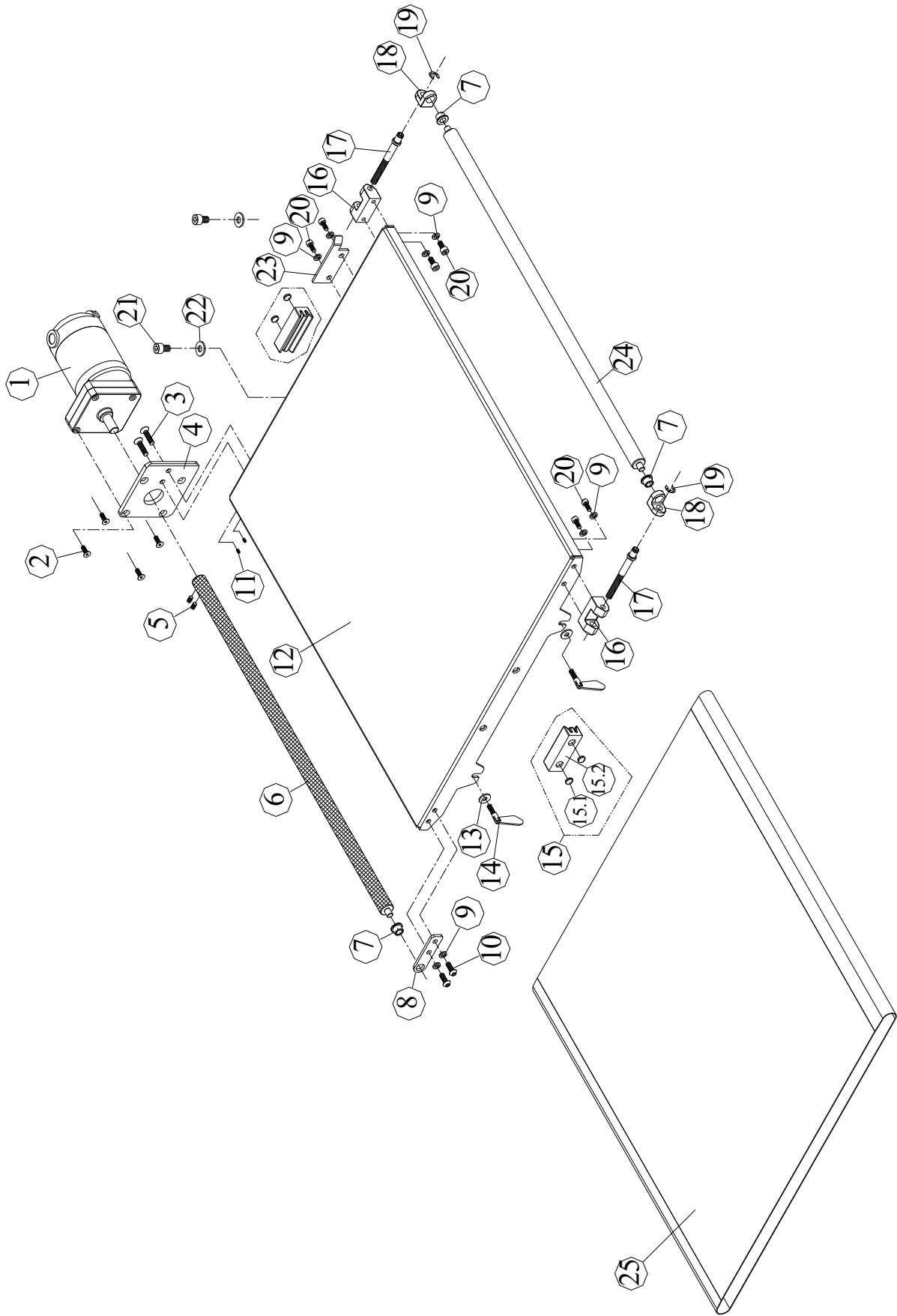

JWDS-2244OSC-M Conveyor Table Assembly – Parts List

Index No	Part No	Description	Size	Qty
1	JWDS2244-201E	Belt Motor	1/30HP 230V	1
2	F010839	Socket Head Flat Screw	#10 x 32UNC x 1/2IN L	4
3	F010985	Socket Head Flat Screw	M6-1.0P x 35L	2
4	JWDS1632-204	Belt Motor Plate		1
5	TS-1522011	Socket Head Set Screw	M5-0.8P x 5L	2
6	JWDS2550-206	Drive Roller		1
7	PM2244-130	Oilite Bushing		3
8	JWDS1632-208	Drive Roller Bracket		1
9	TS-2361061	Lock Washer	M6	8
10	TS-2246162	Socket Head Button Screw	M6-1.0P x 16L	2
11	TS-1521021	Socket Head Set Screw	M4-0.7P x 5L	2
12	JWDS2550-212	Conveyor Table		1
13	TS-1550041	Flat Washer	6.5 x 19 x 2T	2
14	JWDS2550-214	Wing Screw		2
15	PM2244-213	Tracker Kit (set of 2)		1
16	JWDS1632-217	Adjusting Rod Bracket		2
17	JWDS1632-218	Adjusting Rod		2
18	JWDS1632-219	Driven Roller Bracket		2
19	JWDS1632-220	E-Retaining Ring	ETW-7	2
20	TS-1503031	Socket Head Cap Screw	M6-1.0P x 12L	6
21	TS-1504021	Socket Head Cap Screw	M8-1.25P x 12L	2
22	TS-1550061	Flat Washer	8.5 x 19 x 2T	2
23	JWDS1632-224	Guide Plate		1
24	JWDS2550-224	Driven Roller		1
25	JWDS2550-225	Conveyor Belt		1
26	JWDS1632-227E	Conveyor Motor Label (not shown)		1
27	LM000236E	Caution Label – Table Lock (not shown)		1

JWDS-2244OSC-M Closed Stand Assembly – Exploded View

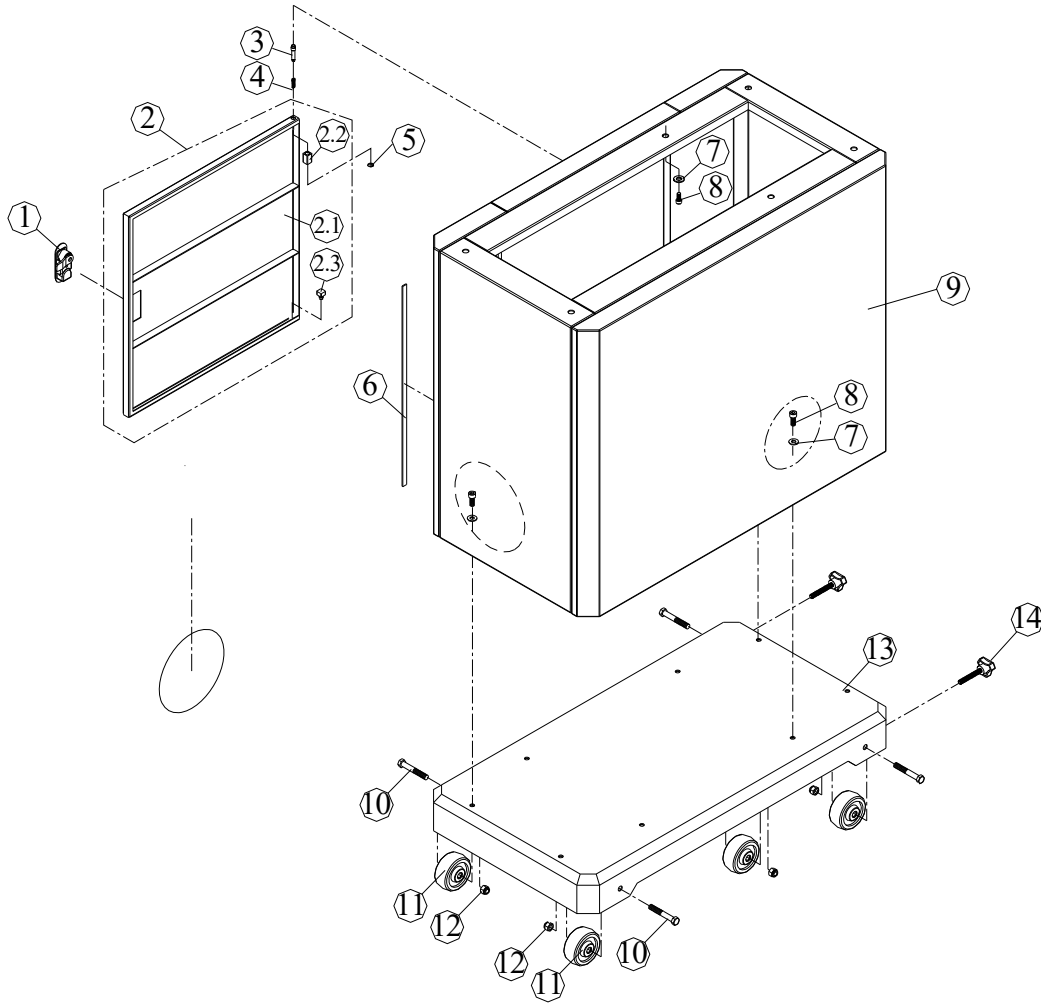

JWDS-2244OSC-M Closed Stand Assembly – Parts List

Index No	Part No	Description	Size	Qty
.....	723544CS.....	Closed Stand Assembly (#1 thru 14)		
1.....	JOSS-S-245.....	Door Latch		1
2.....	JWDS2550-702	Cabinet Door		1
3.....	JOSS-S-242.....	Door Pivot		1
4.....	JOSS-S-243.....	Compression Spring		1
5.....	6286482.....	E-Retaining Ring Ext.	ETW-4	1
6.....	JWDS2550-706	Foam Strip		1
7.....	TS-1550061.....	Flat Washer	8.3 x 18 x 1.5T.....	14
8.....	TS-1504031.....	Socket Head Cap Screw	M8-1.25P x 16L.....	14
9.....	JWDS2550-709	Cabinet		1
10.....	TS-0060111.....	Hex Cap Screw.....	3/8"-16UNC x 2-1/2"L	4
11.....	PJE-S05	Wheel		4
12.....	TS-0640091.....	Nylon Lock Hex Nut.....	3/8"-16UNC	4
13.....	JWDS2550-713	Base		1
14.....	JWDS2550-714	Knob		2

JWDS-2244OSC-M Infeed and Outfeed Tables (OPTIONAL) – Exploded View

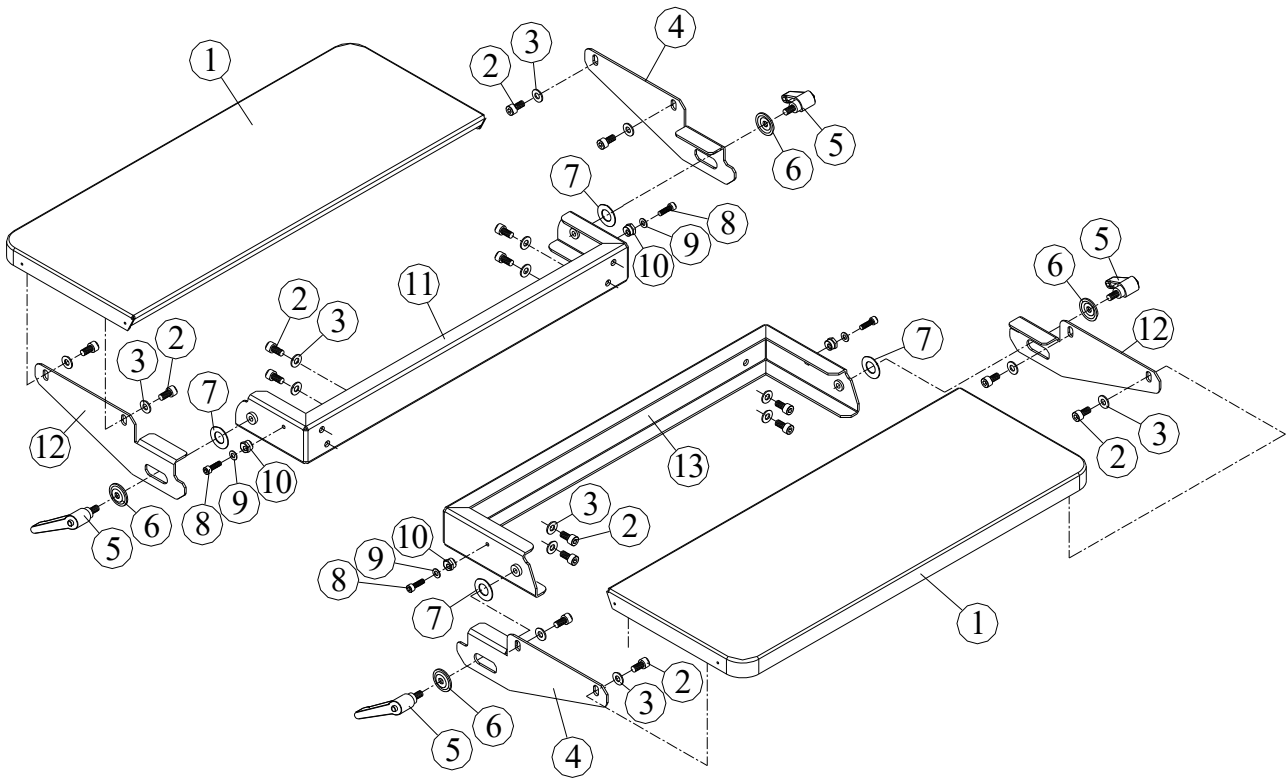

JWDS-2244OSC-M Infeed and Outfeed Tables (OPTIONAL) – Parts List

Index No	Part No	Description	Size	Qty
.....	723551.....	Infeed/Outfeed Table Kit, JWDS-2550 (includes #1-13).....		1
1.....	JWDS2550-401	Extension Table		2
2.....	TS-1504031.....	Socket Head Cap Screw	M8-1.25P x 16L	16
3.....	TS-1550061.....	Flat Washer	8.3 x 20 x 1.5T	16
4.....	JWDS2244-404	Left Folding Table Bracket.....		2
5.....	JWDS2244-405	Handle		4
6.....	JWDS2244-406	Disc Washer.....		4
7.....	JWDS2244-407	Oilite Washer.....		4
8.....	TS-1503051.....	Socket Head Cap Screw	M6-1.0P x 20L	4
9.....	TS-1550041.....	Flat Washer	6.3 x 13 x 2T.....	4
10.....	JWDS2244-410	Eccentric Cam.....		4
11.....	JWDS2550-411	Rear Fixed Bracket.....		1
12.....	JWDS2244-412	Right Folding Table Bracket.....		2
13.....	JWDS2550-413	Front Fixed Bracket		1

JWDS-2244OSC-M Digital Reading (OPTIONAL) – Exploded View

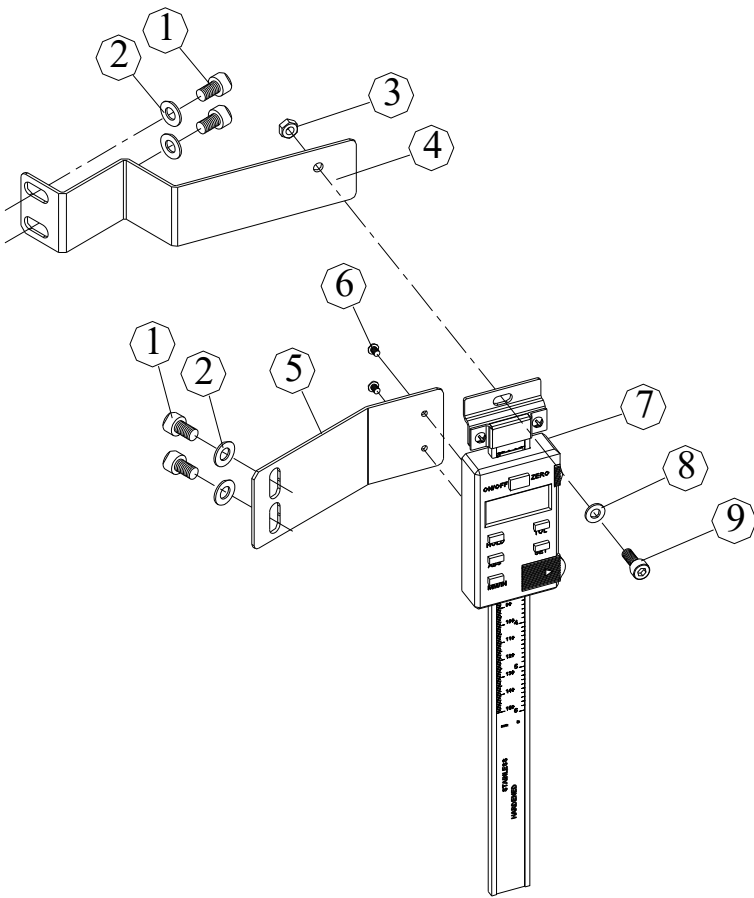

JWDS-2244-M Digital Reading (OPTIONAL) – Parts List

Index No	Part No	Description	Size	Qty
.....	723552.....	Drum Sander DRO Assembly (includes #1 thru 9).....
1.....	TS-1503021.....	Socket Head Cap Screw.....	M6-1.0P x 10L.....	4
2.....	TS-1550041.....	Flat Washer.....	6.5 x 13 x 1T.....	4
3.....	TS-1540031.....	Hex Nut.....	M5-0.8P.....	1
4.....	JWDS2244-504.....	Upper Bracket.....	1
5.....	JWDS2244-505.....	Lower Bracket.....	1
6.....	JWDS2244-506.....	Phillips Round Hd Machine Screw.....	M3-0.5P x 5L.....	2
7.....	JWDS2244-507.....	DRO.....	1
8.....	TS-1550031.....	Flat Washer.....	5.1 x 10 x 1T.....	1
9.....	TS-1502031.....	Socket Head Cap Screw.....	M5-0.8P x 12L.....	1

JWDS-2244OSC-M.....723544OSCKM.....1~230V, 50Hz

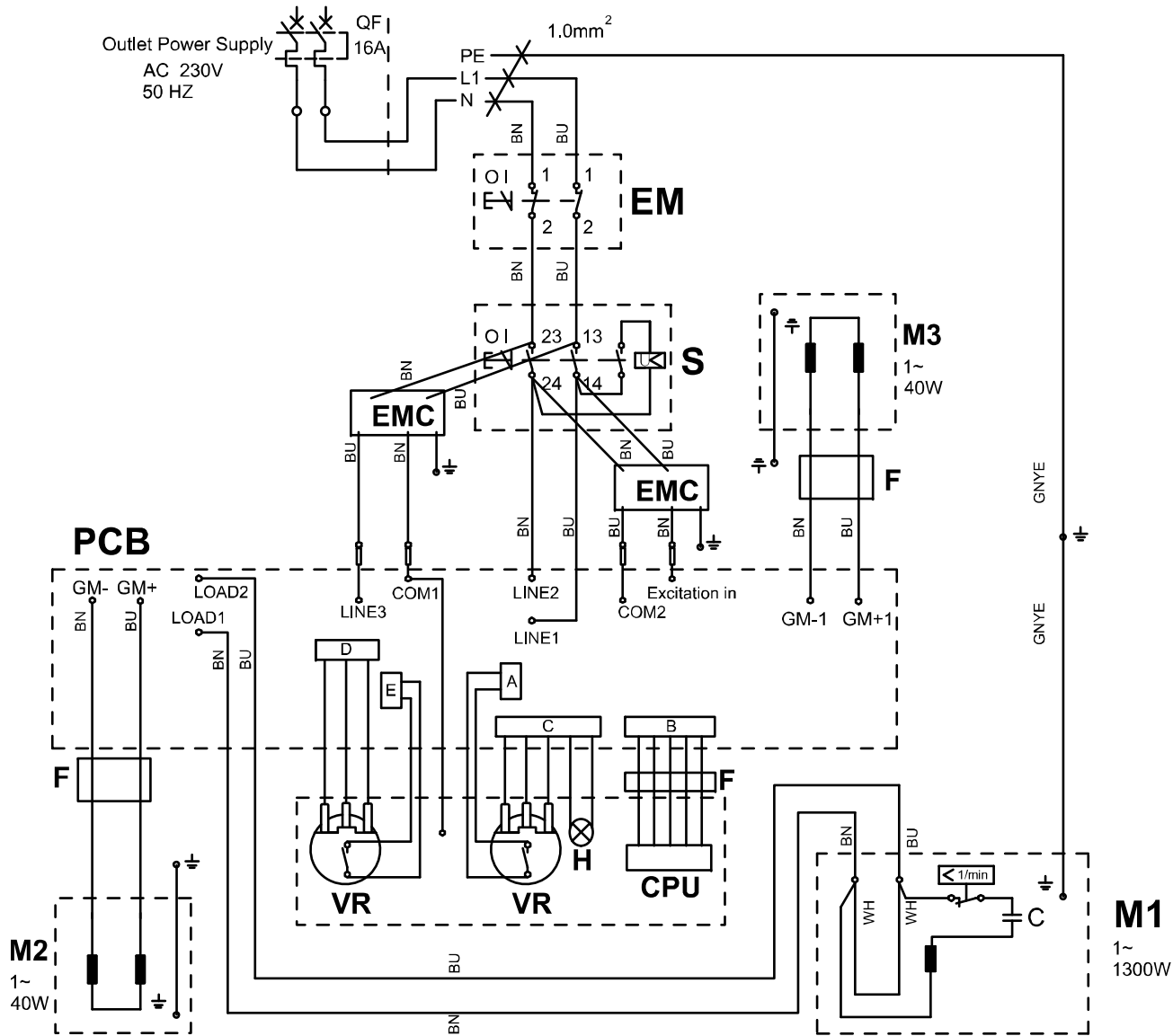

	colour of strands	Litzenfarben	couleur des cordons
BK	black	schwarz	noir
WH	white	weiß	blanc
BU	blue	blau	bleu
YE	yellow	gelb	jaune
RD	red	rot	rouge
BN	brown	braun	brun
GY	grey	grau	gris
GNYE	green-yellow	grün-gelb	vert-jaune
OG	orange	orange	orange
VT	violet	violett	violet

	meaning of symbol	bedeutung der zeichen	interprétation
M1	motor	motor	moteur
M2	motor	motor	moteur
M3	motor	motor	moteur
S	switch	schalter	interrupteur
EM	e-stop	not-Aus Taster	d'urgence
C	condenser	kondensator	condensateur
VR	potentiometer	potentiometer	potentiomètre
EMC	filter	filter	filtre
PCB	circuit board	leiterplatte	carte circuit
H	indication light	anzeigelicht	la lumière d'indication
F	ferrite core	ferritkerne	noyau de ferrite