



MBS-910CSE Miter Bandsaw

MBS-910CSE.... 50000321T 3~400V, 50Hz

PARTS LIST

JPW (Tool) AG.
Ackerstrasse 45
CH-8610 Uster
Switzerland.

www.jettools.com

P-50000321T

2020-04

MBS-910CSE Stand Assembly

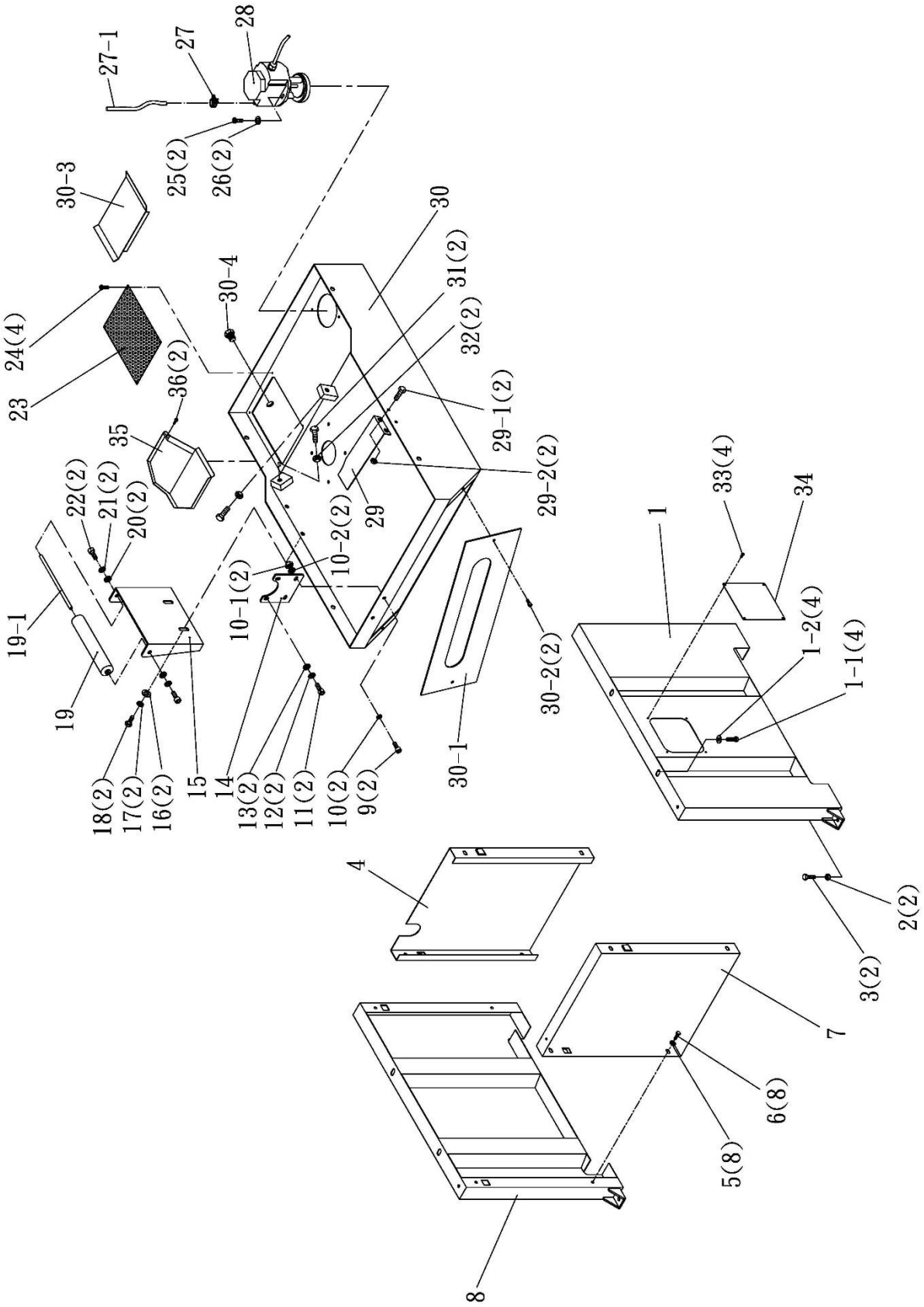

MBS-910CSE Stand Assembly

Index No.	Part No.	Description	Size	Q'ty
1	MBS-910CSP-1	Base (Right Part)		1
1-1	TS-1491021E	Hex. Cap Bolt	M10x20	4
1-2	MBS-910CSE-1-2	Washer	10x25x2	4
2	MBS-910CSE-2	Nut	M12	2
3	TS-1492041E	Hex. Cap Bolt	M12x40	2
4	MBS-910CSP-3	Base (Rear Part)		1
5	MBS-910CSE-5	Washer	8x18x2	8
6	TS-2228161E	Hex. Cap Bolt	M8x16	8
7	MBS-910CSP-4	Base (Front Part)		1
8	MBS-910CSP-5	Base (Left Part)		1
9	TS-1504041E	Hex. Socket Cap Screw	M8x20	2
10	MBS-910CSE-10	Spring Washer	M8	2
10-1	MBS-910CSE-10-1	Nut	M8	2
10-2	MBS-910CSE-10-2	Washer	8x18x2	2
11	TS-1504041E	Hex. Socket Cap Screw	M8x20	2
12	MBS-910CSE-12	Spring Washer	M8	2
13	MBS-910CSE-13	Washer	8x18x2	2
14	MBS-910CSE-14	Supporting Plate		1
	MBS-910CSE-RSA	Roller Stand Assembly (including 15, 19~22)		
15	MBS-910CSE-15	Roller Stand Bracket		1
16	MBS-910CSE-16	Washer	10x25x2	2
17	MBS-910CSE-17	Spring Washer	M10	2
18	TS-1491021E	Hex. Cap Bolt	M10x20	2
19	MBS-910CSE-19	Roller		1
19-1	MBS-910CSE-19-1	Roller Shaft		1
20	MBS-910CSE-20	Washer	8x18x2	2
21	MBS-910CSE-21	Spring Washer	M8	2
22	TS-1504041E	Hex. Socket Cap Screw	M8x20	2
23	MBS-708CSP-18	Filter Net		1
24	MBS-910CSE-24	Round Head Screw	M5x10	4
25	TS-1503061E	Hex. Socket Cap Screw	M6x25	2
26	MBS-910CSE-26	Washer	6x13x1	2
27	MBS-910CSE-27	Hose Clamp	13mm	1
27-1	MBS-910CSE-27-1	Hose	5/16x130cm	1
28	MBS-708CSP-23	Pump	32W 400V 1 Ph	1
29	MBS-910CSE-29	Plate		1
29-1	TS-1482031E	Hex. Cap Bolt	M6x16	2
29-2	MBS-910CSE-29-2	Nut	M6	2
30	MBS-910CSE-30	Coolant and Chip Tray		1
30-1	MBS-910CSE-30-1	Front Plate		1
30-2	TS-1503011E	Hex. Socket Cap Screw	M6x8	2
30-3	MBS-1011DAP-70	Coolant Plate		1
30-4	MBS-910CSE-30-4	Plug	M3/8"	1
31	TS-1492041E	Hex. Cap Bolt	M12x40	2
32	MBS-910CSE-32	Nut	M12	2
33	TS-1502011E	Hex. Socket Cap Screw	M5x8	4
34	MBS-910CSP-2	Plate		1
35	MBS-910CSP-17	Coolant Tray		1
36	TS-1502011E	Hex. Socket Cap Screw	M5x8	2

MBS-910CSE Swivel & Base Assembly

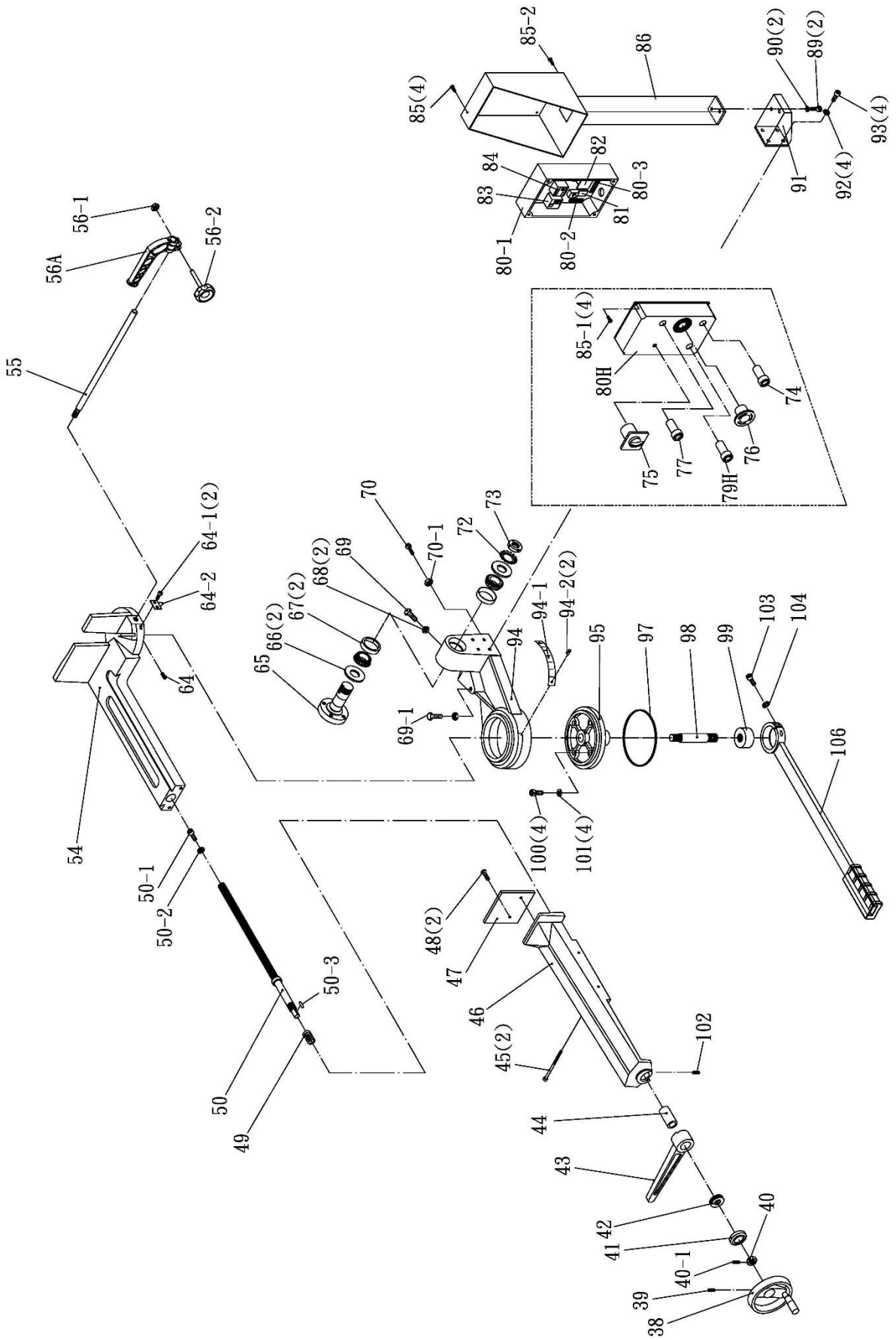

MBS-910CSE Swivel & Base Assembly

Index No.	Part No.	Description	Size	Q'ty
38	MBS-1011DAP-154	Hand Wheel	6-1/2"	1
39	TS-1524021E	Set Screw	M8x10	1
40	MBS-910CSE-40	Nut	M20x30x9P1.5	1
40-1	MBS-910CSE-40-1	Set Screw	M5x5	1
41	MBS-910CSE-41	Bearing Bushing		1
42	BB-51104E	Bearing	51104	1
43	MBS-708CSP-59	Lock Handle		1
44	MBS-910CSE-44	Bushing		1
45	MBS-910CSE-45	Hex. Socket Cap Screw	M6x100	2
46	MBS-910CSE-46	Movable Vise		1
47	MBS-910CSE-47	Plate		1
48	MBS-910CSE-48	Flat Head Machine Screw	M6x16	2
49	MBS-910CSE-49	Compressed Spring	5x31x35mm	1
50	MBS-910CSE-50	Lead Screw		1
50-1	TS-1504031E	Hex. Socket Cap Screw	M8x16	1
50-2	MBS-910CSE-50-2	Washer	8x18x2	1
50-3	MBS-910CSE-50-3	Key	5x5x15	1
54	MBS-910CSE-54	Vise Table		1
	MBS-910CSE-SRA	Stop-Rod Assembly (including 55~56-2)		
55	MBS-910CSE-55	Bar-Stop-Rod		1
56A	MBS-708CSP-83	Bar-Stop	Ø19	1
56-1	MBS-708CSP-83-1	Nut	M8	1
56-2	MBS-708CSP-83-2	Knob	M8x30	1
64	TS-1524021E	Set Screw	M8x10	1
64-1	TS-1522021E	Hex. Socket Cap Screw	M5x8	2
64-2	MBS-910CSE-64-2	Scale Point		1
65	MBS-910CSE-65	Pivot		1
66	MBS-910CSE-66	Anti-Dust Cover	30mm	2
67	BB-32006E	Bearing	32006	2
68	MBS-910CSE-68	Nut	M10	2
69	TS-1491031E	Hex. Cap Bolt	M10x25	1
69-1	TS-1491031E	Hex. Cap Bolt	M10x25	1
70	MBS-910CSE-70	Spring Hook		1
70-1	MBS-910CSE-70-1	Nut	M12	1
72	MBS-910CSE-72	Star Washer	M30	1
73	MBS-910CSE-73	Nut	M30xP1.5	1
74	MBS-910CSE-74	Stop Button		1
75	MBS-910CSE-75	Main Connect Switch		1
76	MBS-910CSE-76	Emergency Stop Switch		1
77	MBS-910CSE-77	Power Indicator Light		1
79H	MBS-910CSE-79H	Start Button		1
80H	MBS-910CSE-80H	PVC Panel		1
80-1	MBS-910CSE-80-1	Plastic Box		1
80-2	MBS-910CSE-80-2	Terminal Connector		1
80-3	MBS-910CSE-80-3	Grounding Plate		1
81	MBS-1011DAP-35	Fuse	2A	1
82	MBS-910CSE-82	Transformer		1
83	MBS-910CSE-83	Overload Relay		1
84	MBS-910CSE-84	Magnetic Connector	C-12D	1
85	MBS-910CSE-85	Round Head Screw	M4x8	4
85-1	MBS-910CSE-85-1	Round Head Screw	M4x12	4
85-2	MBS-910CSE-85-2	Round Head Screw	M4x25	1
86	MBS-910CSE-86	Control Bracket		1
89	TS-1504041E	Hex. Socket Cap Screw	M8x20	2
90	MBS-910CSE-90	Spring Washer	M8	2
91	MBS-910CSE-91	Setting Bracket		1
92	MBS-910CSE-92	Spring Washer	M8	4

Index No.	Part No.	Description	Size	Q'ty
93	TS-1504041E	Hex. Socket Cap Screw	M8x20	4
94	MBS-910CSE-94	Swivel Arm		1
94-1	MBS-910CSE-94-1	Scale		1
94-2	MBS-910CSE-94-2	Rivet	2.3x4	2
95	MBS-910CSE-95	Disk		1
97	MBS-910CSE-97	Oil Seal	4mmx518mm	1
98	MBS-910CSE-98	Shaft		1
99	MBS-910CSE-99	Nut		1
100	TS-1504061E	Hex. Socket Cap Screw	M8x30	4
101	MBS-910CSE-101	Spring Washer	M8	4
102	MBS-910CSE-102	Set Screw	M8x10	1
103	TS-1503061E	Hex. Socket Cap Screw	M6x25	1
104	MBS-910CSE-104	Spring Washer	M6	1
106	MBS-910CSE-106	Locking Lever		1

MBS-910CSE Bow Assembly

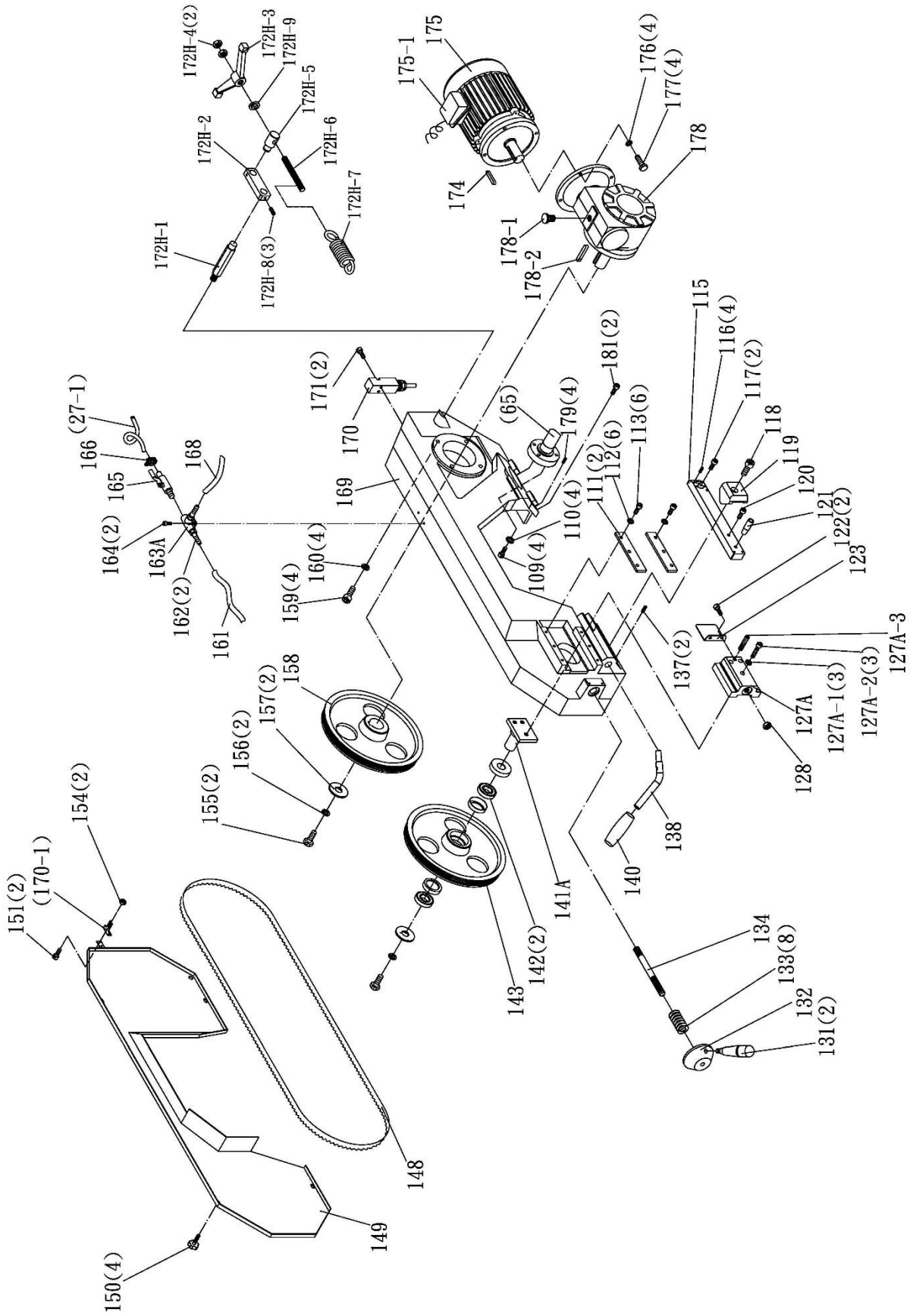

MBS-910CSE Bow Assembly

Index No.	Part No.	Description	Size	Q'ty
109	TS-1505041E	Hex. Socket Cap Screw	M10x30	4
110	MBS-910CSE-110	Spring Washer	M10	4
111	MBS-910CSE-111	Gib		2
112	MBS-910CSE-112	Spring Washer	M8	6
113	TS-1504041E	Hex. Socket Cap Screw	M8x20	6
115	MBS-910CSE-115	Front Ball Bearing Bracket		1
116	TS-1523041E	Set Screw	M6x12	4
117	TS-1504041E	Hex. Socket Cap Screw	M8x20	2
118	MBS-910CSE-118	Hex. Socket Cap Screw	M12x50	1
119	MBS-910CSE-119	Setting Bracket		1
120	TS-1503011E	Hex. Socket Cap Screw	M6x8	1
121	MBS-910CSP-127	Plastic Handle	M6x60	1
122	TS-1503011E	Hex. Socket Cap Screw	M6x8	2
123	MBS-910CSE-123	Cover Plate		1
127A	MBS-910CSE-127A	Slide		1
127A-1	MBS-910CSE-127A-1	Spring Washer	M10	3
127A-2	MBS-910CSE-127A-2	Hex. Socket Cap Screw	M10x45	3
127A-3	MBS-910CSE-127A-3	Set Screw	M10x25	1
128	MBS-910CSE-128	Nut	M16	1
131	MBS-910CSE-131	Handle		2
132	MBS-910CSE-132	Handle Wheel		1
133	MBS-910CSE-133	Thrust Spring Washer		8
134	MBS-910CSE-134	Tension Shaft		1
137	TS-1524021E	Set Screw	M8x10	2
138	MBS-910CSP-112	Rod		1
140	MBS-910CSP-110	Handle		1
141A	MBS-910CSE-141A	Shaft		1
142	BB-6006ZZE	Bearing	6006ZZ	2
143	MBS-910CSE-143	Idle Flywheel		1
148	MBS-910CSP-133	Blade	27x0.9x2460 5/8T	1
149	MBS-910CSE-149	Blade Cover		1
150	MBS-910CSE-150	Knob Bolt	M6x12	4
151	MBS-910CSE-151	Round Head Screw	M4x8	2
154	MBS-910CSE-154	Nut	M4	2
155	TS-1491031E	Hex. Cap Bolt	M10x25	2
156	MBS-910CSE-156	Spring Washer	M10	2
157	MBS-910CSE-157	Washer		2
158	MBS-910CSE-158	Drive Flywheel		1
159	TS-1505061E	Hex. Socket Cap Screw	M10x40	4
160	MBS-910CSE-160	Spring Washer	M10	4
161	MBS-910CSE-161	Hose	5/16x90cm	1
162	MBS-910CSE-162	Pipe Fitting	1/4Px5/16	2
163A	MBS-910CSE-163A	T Connector		1
164	TS-1502041E	Hex. Socket Cap Screw	M5x16	2
165	MBS-910CSE-165	Coolant Switch	1/4Px5/16	1
166	MBS-910CSE-166	Hose Clamp	13mm	1
168	MBS-910CSE-168	Hose	5/16x40cm	1
169	MBS-910CSE-169	Saw Arm		1
170	MBS-910CSE-170	Limit Switch	QKS8	1
170-1	MBS-910CSE-170-1	Switch Pin		1
171	TS-1501081E	Hex. Socket Cap Screw	M4x30	2
172H-1	MBS-910CSE-172H-1	Spring Shaft		1
172H-2	MBS-910CSE-172H-2	Setting Plate		1
172H-3	MBS-910CSE-172H-3	Handle		1
172H-4	MBS-910CSE-172H-4	Nut	M16	2
172H-5	MBS-910CSE-172H-5	Bushing		1
172H-6	MBS-910CSE-172H-6	Adjustable Shaft	16x160mm	1
172H-7	MBS-910CSE-172H-7	Spring	6x50x188mm	1

Index No.	Part No.	Description	Size	Q'ty
172H-8	TS-1524021E	Set Screw	M8x10	3
172H-9	MBS-910CSE-172H-9	Washer	16x30x3	1
174	MBS-910CSP-88	Key	6x6x30	1
175	MBS-910CSP-86	Motor	1.1/0.56kW 4/8P	1
175-1	MBS-910CSP-87	Junction Box		1
176	MBS-910CSE-176	Spring Washer	M8	4
177	TS-1490051E	Hex. Cap Bolt	M8x30	4
178	MBS-910CSE-178	Gear Box		1
178-1	MBS-910CSE-178-1	Vent Screw		1
178-2	MBS-910CSE-178-2	Key	8x7x40	1
179	TS-1523041E	Set Screw	M6x12	4
181	TS-1504041E	Hex. Socket Cap Screw	M8x20	2

MBS-910CSE Bearing Guide Assembly

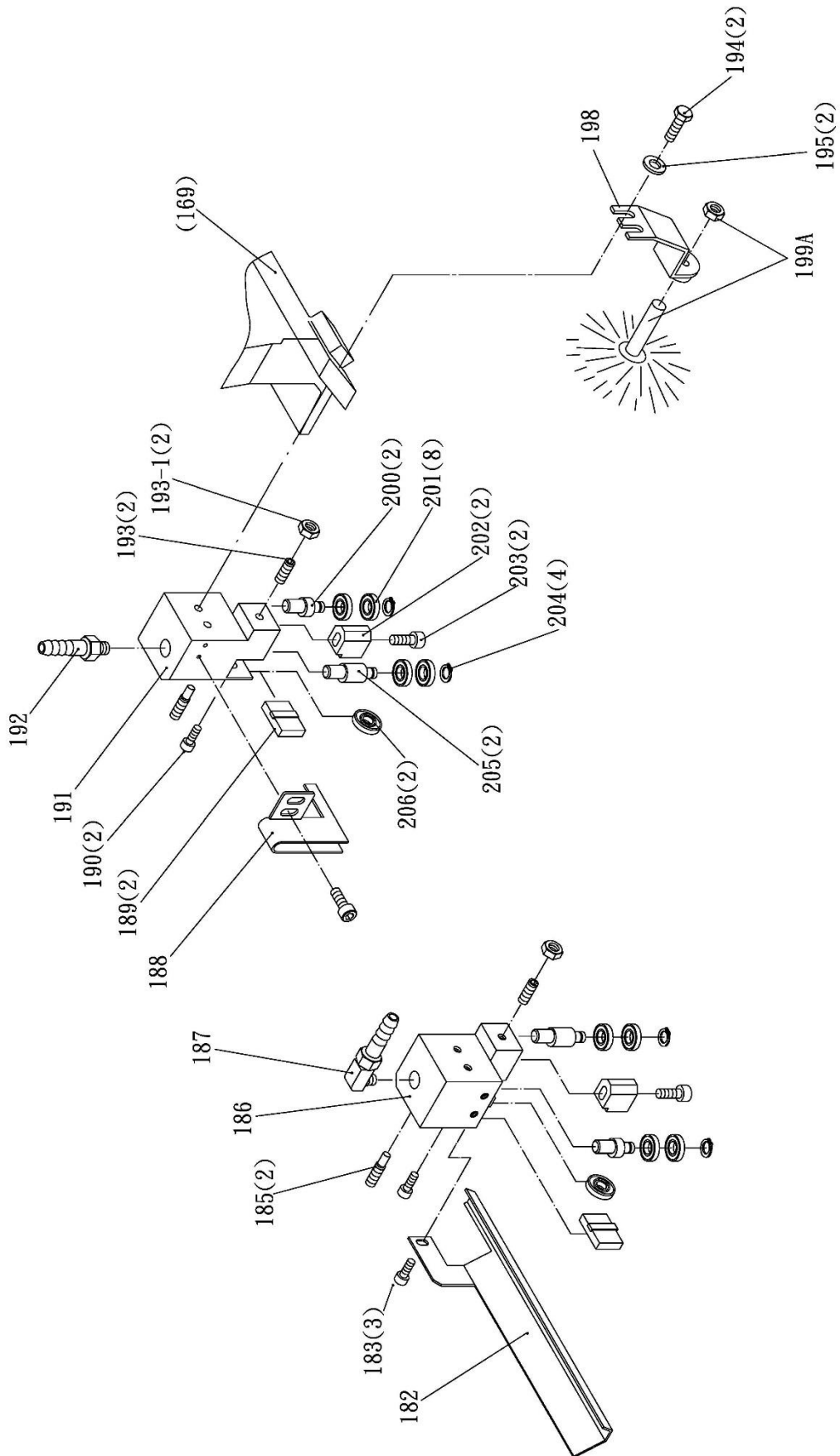

MBS-910CSP Bearing Guide Assembly

Index No.	Part No.	Description	Size	Q'ty
182	EHB-270DGSVIP-292	Blade Guard		1
183	TS-1503011E	Hex. Socket Cap Screw	M6x8	3
185	EHB-270DGSVIP-290	Bolt		2
186	EHB-270DGSVIP-289	Guide Bracket		1
187	MBS-910CSE-187	Pipe Fitting	1/4Px5/16	1
188	EHB-270DGSVIP-303	Blade Guard		1
189	EHB-270DGSVIP-307	Blade Guide		2
190	TS-1503011E	Hex. Socket Cap Screw	M6x8	2
191	EHB-270DGSVIP-304	Guide Bracket		1
192	EHB-270DGSVIP-306	Pipe Fitting	1/4Px5/16	1
193	TS-1523041E	Set Screw	M6x12	2
193-1	EHB-270DGSVIP-294	Nut	M6	2
194	TS-1482021E	Hex. Cap Bolt	M6x12	2
195	MBS-910CSE-195	Washer	6x13x1	2
198	MBS-910CSE-198	Bracket		1
199A	MBS-910CSE-199A	Brush With Nut	Ø50	1
200	MBS-910CSE-200	Eccentric Shaft		2
201	MBS-910CSE-201	Ball Bearing	608ZZ	8
202	EHB-270DGSVIP-298	Blade Guide		2
203	TS-1503061E	Hex. Socket Cap Screw	M6x25	2
204	EHB-270DGSVIP-297	E Ring	E-7	4
205	EHB-270DGSVIP-295	Centric Shaft		2
206	BB-608ZZE	Ball Bearing	608ZZ	2

MBS-910CSE Hydraulic Cylinder Assembly

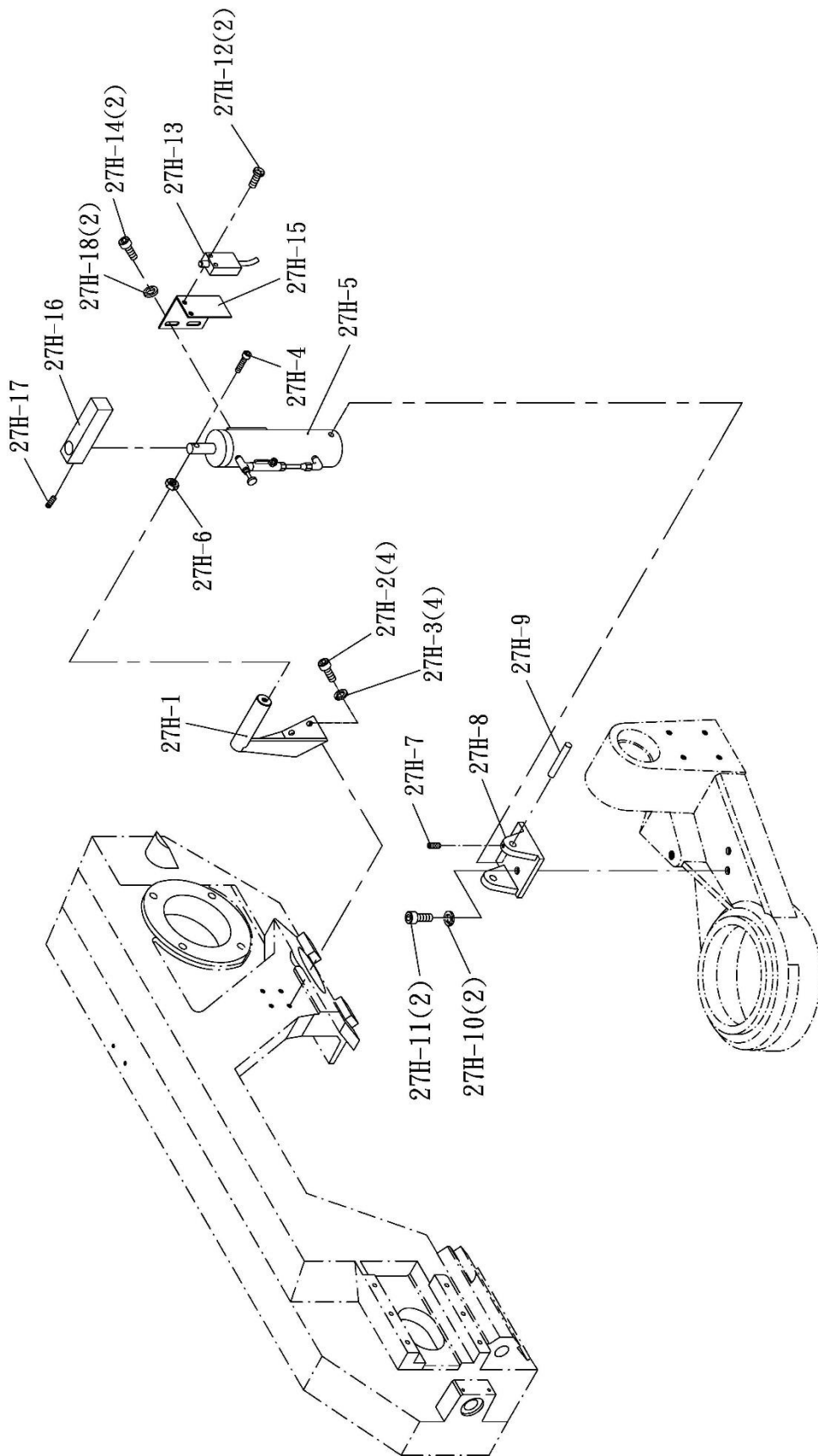

MBS-910CSE Hydraulic Cylinder Assembly

Index No.	Part No.	Description	Size	Q'ty
27H-1	MBS-910CSE-27H-1	Top Support		1
27H-2	TS-1504041E	Hex. Socket Cap Screw	M8x20	4
27H-3	MBS-910CSE-27H-3	Spring Washer	M8	4
27H-4	MBS-910CSE-27H-4	Hex. Socket Cap Screw	M10x40	1
27H-5	MBS-910CSE-27H-5	Hydraulic Cylinder		1
27H-6	MBS-910CSE-27H-6	Nut	M10	1
27H-7	TS-1523041E	Set Screw	M6x12	1
27H-8	MBS-910CSE-27H-8	Bottom Support		1
27H-9	MBS-910CSE-27H-9	Support Rod		1
27H-10	MBS-910CSE-27H-10	Spring Washer	M8	2
27H-11	TS-1504041E	Hex. Socket Cap Screw	M8x20	2
27H-12	MBS-910CSE-27H-12	Round Head Screw	M5x10	2
27H-13	MBS-910CSE-27H-13	Limit Switch	TZ-8111	1
27H-14	TS-1503011E	Hex. Socket Cap Screw	M6x8	2
27H-15	MBS-910CSE-27H-15	Adjusting Bracket		1
27H-16	MBS-910CSE-27H-16	Setting Bracket		1
27H-17	TS-1523041E	Set Screw	M6x12	1
27H-18	MBS-910CSE-27H-18	Washer	6x13x1	2

MBS-910CSE...5000321T...3~400V, 50Hz

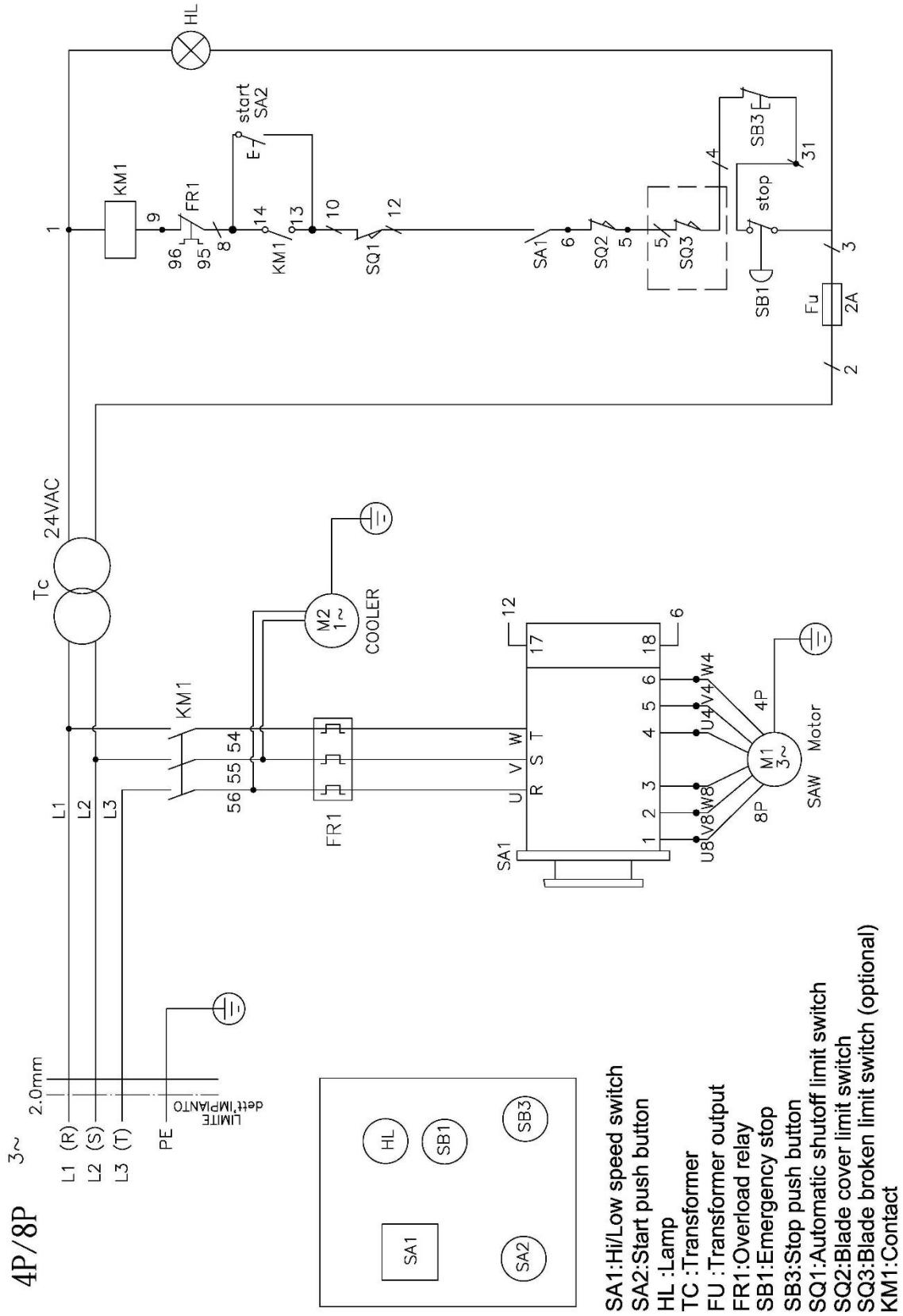

- SA1: Hi/Low speed switch
- SA2: Start push button
- HL : Lamp
- TC : Transformer
- FU : Transformer output
- FR1: Overload relay
- SB1: Emergency stop
- SB3: Stop push button
- SQ1: Automatic shutoff limit switch
- SQ2: Blade cover limit switch
- SQ3: Blade broken limit switch (optional)
- KM1: Contact